

POLE PULLER

⚠ WARNING

Cancer and Reproductive Harm: www.P65Warnings.ca.gov

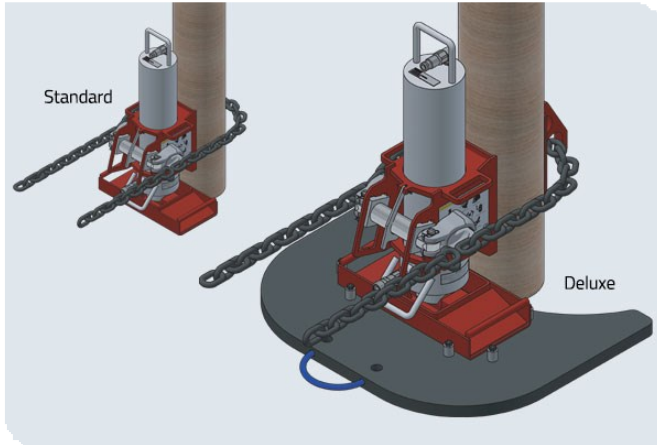

KEY FEATURES

- ✓ Low point of attachment
- ✓ 50,120 lbs lift at max pressure
- ✓ Deluxe System complete with back plate weldment & pad

Slingco's pole puller is a must have to comply with today's safe working practices, reducing the potential for boom damage and greatly reducing the potential of personal injury. The pole puller is easily assembled and disassembled.

The standard pole puller system is composed of four pieces and the deluxe system six pieces. These configurations make the Slingco pole puller easy to handle and lighter weight than typical units on the market.

The Slingco Deluxe Pole Puller system includes the pole puller pad and back plate weldment. The pole puller pad has studs which keep the base plate in the optimum position when pulling poles. The back plate weldment has angled teeth to increase hold on the pole during extraction.

Slingco's pole puller offers a low point of attachment making it easy to remove even broken or cut poles.

Slingco Part No.	Description	Max Operating Pressure (PSI)	Recommended Flow Rate (GPM)	Lift at Max Pressure (lb)	Lift at Max Pressure (kg)	Total Weight (lb)	Total Weight (kg)
TPE09386	DELUXE Pole Puller System consists of: hydraulic cylinder*, chain, base weldment, swivel assembly PLUS back plate weldment, and pole puller pad.	2,800	4 - 8	50,120	22,734	157	71.2
TPE10551	STANDARD Pole Puller System consists of: hydraulic cylinder*, chain, base weldment, swivel assembly.	2,800	4 - 8	50,120	22,734	128	58
TPE09378	Pole Puller Pad					23	10.43
TPE09367	Back Plate Weldment					6	2.72

Note

*hydraulic cylinder comes with flush face fittings installed.

This information is for marketing purposes only. The details contained herein is presented as general information and no representation or warranty is expressly or impliedly given as to its accuracy, completeness or correctness. It does not constitute part of a legal offer or contract. For technical specifications, please contact Slingco Australia Pty. Ltd



L9, 1 York Street, Sydney, NSW 2000, Australia Sales: +61 3 8840 6556

GET IN TOUCH

+61 3 8840 6556

sales@slingcoaustralia.com.au

POLE PULLER

Dimensions

The figures shown are indicative only. Fully dimensioned data-sheets are available on request. Nominal figures/actuals are as per data-sheet with tolerances of +/-10%. Please contact us if you have any questions.

Range dimension overlaps If the cable, rope or hose you have lies where ranges overlap, e.g. 1" when sizing is 0.5-1.00 and 1.00-1.5 we recommend that you select your cable grip to achieve break load first. If tensile strengths are equal or both adequate, choose the smaller of the two. Please contact us if you have any questions.



L9, 1 York Street, Sydney, NSW 2000, Australia Sales: +61 3 8840 6556

GET IN TOUCH



+61 3 8840 6556



sales@slingcoaustralia.com.au