

POLE LINE SUSPENSION CLAMPS



KEY FEATURES

- ✓ Safe and quick installation and removal of the conductor.
- ✓ Variety of sizes to accommodate conductors from 0.16 to 1.50 inch diameter
- ✓ All moving parts of the clamps are captive.
- ✓ Made from heat treated aluminium alloy 356-T6 or ductile iron 60-45-15
- ✓ Hot dip galvanised for corrosion resistance

Slingco suspension conductor clamps provide safe and quick installation and removal of the conductor when attached to the insulator. A single fastener fully opens and closes the jaw. The clamps come in a variety of sizes to accommodate conductors from 0.16 to 1.50 inch diameter, and loadings of up to 18,000 lbs. To prevent loss, all moving parts of the clamps are captive.

Depending on size, the clamps are either made from heat treated aluminum alloy 356-T6 or ductile iron 60-45-15 and hot-dip galvanised for corrosion resistance.



GET IN TOUCH

01706 855 558

sales@slingco.com

POLE LINE SUSPENSION CLAMPS

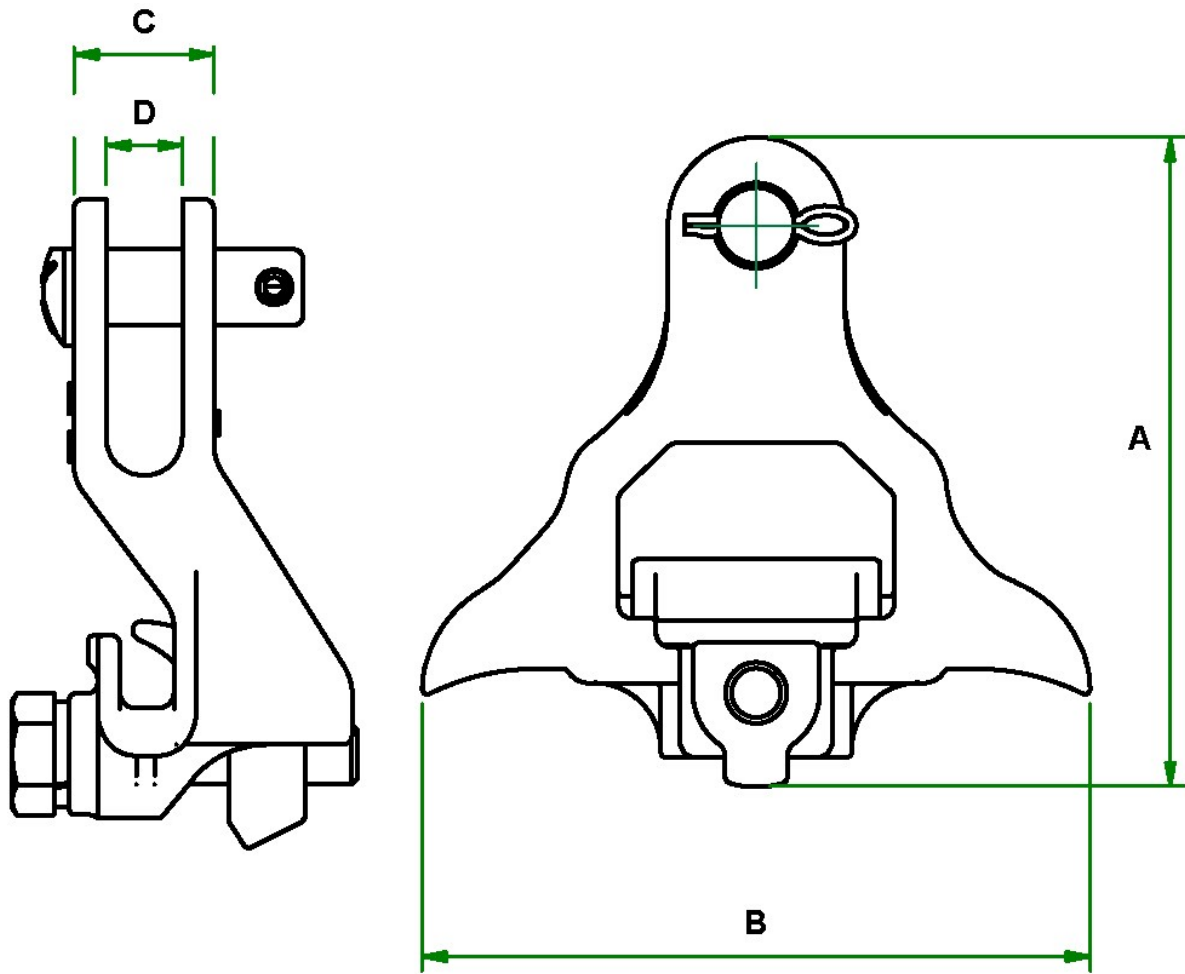

Slingco Part No.	Range (in)	Material	A (in)	B (in)	C (in)	D (in)	Load (lbs)
ZMI6320	0.16 – 0.43	Ductile iron	5.36	5.51	1.16	0.63	10,000
ZMI6321	0.30 – 0.70	Ductile iron	8.03	6.34	1.38	0.63	18,000
ZMI6322	0.50 – 0.687	Aluminium alloy 356-T6	6.22	6.89	1.61	0.63	12,000
ZMI6323	0.68 – 1.00	Aluminium alloy 356-T6	8.37	6.89	1.73	0.63	12,000
ZMI6324	1.00 – 1.313	Aluminium alloy 356-T6	9.53	6.97	1.74	0.63	12,000

This information is for marketing purposes only. The details contained herein is presented as general information and no representation or warranty is expressly or impliedly given as to its accuracy, completeness or correctness. It does not constitute part of a legal offer or contract. For technical specifications, please contact Slingco Limited.

Dimensions

The figures shown are indicative only. Fully dimensioned data-sheets are available on request. Nominal figures/actuals are as per data-sheet with tolerances of +/- 10%. Please contact us if you have any questions.

Range dimension overlaps If the cable, rope or hose you have lies where ranges overlap, e.g. 1" when sizing is 0.5-1.00 and 1.00-1.5 we recommend that you select your cable grip to achieve break load first. If tensile strengths are equal or both adequate, choose the smaller of the two. Please contact us if you have any questions.



GET IN TOUCH

01706 855 558

sales@slingco.com