

GROUNDING CLAMPS

⚠ WARNING

Cancer and Reproductive Harm: www.P65Warnings.ca.gov

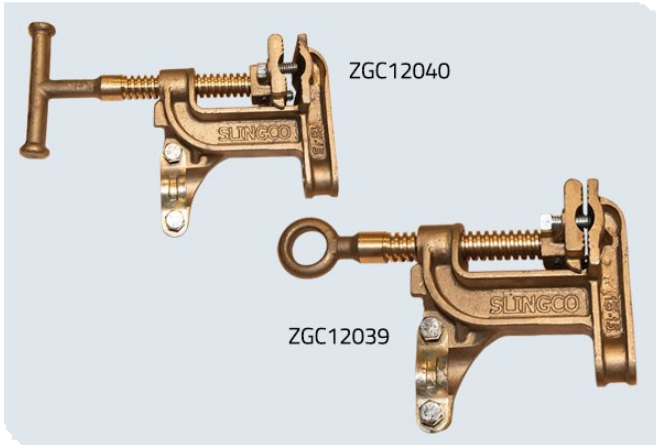

KEY FEATURES

- ✓ Meets ASTM F855 specification
- ✓ Line range up to 2" (50.8 mm)
- ✓ Adjustable to ensure secure connection between clamp and cable

Slingco's grounding clamps meet ASTM F855 and have a maximum line range of up to 2" (50.8mm) which allows them to be used in a wide variety of grounding applications.

Aluminium clamps

Slingco's aluminium grounding clamps have a location for a grounding stud which allows for a wide variety of grounding applications. The Slingco aluminium clamps come with serrated and a smooth jaw offering.

Bronze clamps

Slingco's bronze grounding clamps have set screws in the moveable jaw which allows the user to adjust and make sure there is a secure connection between the clamp and cable. The flat face clamps come with a serrated jaw and are available with a T-handle or Eye Bolt.

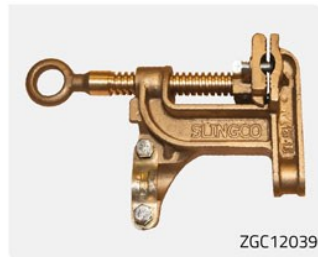
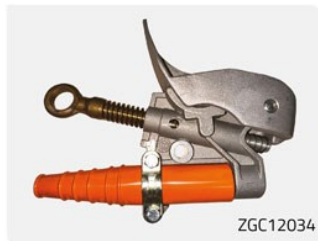
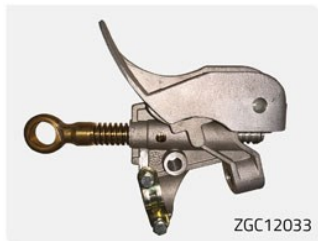

GET IN TOUCH

01706 855 558

sales@slingco.com