



SLINGCO UTILITY PRODUCTS

CABLE INSTALLATION AND SUPPORT
MADE A WHOLE LOT EASIER

A GLOBAL BUSINESS BUILT ON QUALITY, INNOVATION, SERVICE ...AND REAL FAMILY TIES

We've been living and breathing manufacturing for as long as we can remember. You can blame our Dad for that!

He founded Slingco more than 40 years ago. Since then, we've grown up and so has the company, evolving into an expert design and manufacturing operation, producing high quality tools for cable and conductor installation - products that are renowned for high performance in quality-critical applications.

Our head office is in Lancashire, UK, but you'll find our products around the world, making heavy-duty cable installation and support a whole lot easier for people working in industries as varied as public utilities, overhead line construction, oil and gas, marine and offshore, civil engineering, aerospace, transport, the military, performing arts, vehicle building, construction, and more.

You can't make mistakes when you're dealing with products like ours. Too much depends on them. That's why we're obsessive

about quality and innovation in design and manufacturing, and why nothing leaves our hands that isn't 100% dependable.

Because we understand exactly what your operation needs, we also know cost is a factor. We keep our prices realistic and hold a vast range of stock for fast - even same day - delivery.

We're brothers, partners, and the driving force behind Slingco, but we're only a small part of the whole picture. We've got a fantastic team of skilled people who share our obsession with quality and great service. We're proud of every one of them.

Together, we're going to carry on developing outstanding products. We're going to carry on getting them out to you in record time. And we're going to carry on being the sort of company it's a pleasure to deal with.

MATT DYKINS
PRESIDENT, SLINGCO AMERICA

NICK DYKINS
CEO, SLINGCO LIMITED



CABLE GRIPS AND ACCESSORIES

A Type - High Strength Cable Grip (Heavy Duty)	5
Anti Rotational Device	8
Conduit Riser Cable Grip - Stainless Steel	16
Connectors: 90°, Rope To Rope, Rope To Swivel	7
Double Eye Closed Mesh Cable Support Grip	11
Double Eye Split Mesh Lace Closing Cable Support Grip	11
Double Eye Split Mesh Rod Closing Cable Support Grip	11
Extended Thimble Eye Heavy Duty Double Weave Stainless Steel Cable Grip	17
Fast Banding	9
Feed Tube	5
Heavy Duty Support Grips - Single Eye	14
Heavy Duty Support Grips - Single Eye Lace-Up	14
Heavy Duty Support Grips - Single Eye Rod Closing	14
Heavy Duty Support Grips - Double Eye	15
Heavy Duty Support Grips - Double Eye Lace-Up	15
Heavy Duty Support Grips - Double Eye Rod Closing	15
Hooked Eye Riser Pole Cable Support Grip	16
Line Pulling Swivel - Bright Zinc Plated Steel	6
Line Pulling Swivel - Galvanised	6
MU Type - High Strength Cable Grip (Heavy-Medium Duty)	5
Offset Eye Closed Mesh Cable Support Grip	12
Offset Eye Split Mesh Lace Closing Cable Support Grip	12
Offset Eye Split Mesh Rod Closing Cable Support Grip	12
R Type - Rotating Eye Multi-Weave Cable Grip (Underground)	8
RT Type - Rotating Eye Double Weave Cable Grip (Underground)	9
Single Eye Closed Mesh Cable Support Grip	10
Single Eye Split Mesh Lace Closing Cable Support Grip	10
Single Eye Split Mesh Rod Closing Cable Support Grip	10
Universal Eye Closed Mesh Cable Support Grip	13
Universal Eye Split Mesh Lace Closing Cable Support Grip	13
Universal Eye Split Mesh Rod Closing Cable Support Grip	13
Ultra-Flex Single Eye Double Weave Non-Metallic Cable Grip	7
Wind Turbine Support Grip - Heavy Duty Thimble Offset Eye	17
Tri & Quad Pulling Sling	17
LU Type - Lace Up Cable Grip	18
SE Type - Single Eye Cable Grip (Medium-Light Duty)	18
ST Type - Single Eye Double Weave Cable Grip (Medium Duty)	19
OS Type - Offset Eye Cable Grip	19
Junior Type Cable Grip (Light Duty)	19
Directional Drilling Swivels	20
Open Ended Cable Grip	20
Reinforced Eye Underground Grips	21

CATCHBLOCK

Bollard Clamp	24
Catchblock Overhead Line Catenary Roller	22-23
Conductor Replacement Roller	25
Remotely Operated Cable Tug Unit	24
High Voltage Pulling Rope (HVPR)	25

CONDUCTOR SUPPORT

Fibreglass Extension Arm	26
Jib Head Adapter	26

GROUNDING AND JUMPER

35kv Jumper Clamp	27
Grounding Clamps	27

CUTTING TOOLS

Bolt Cutters	28
Ratchet Cutters	28

CRIMPING TOOLS

Mechanical Crimping Tool	29
60 Ton Hydraulic Crimping Tool	30
100 Ton Hydraulic Crimping Tool	31

LIVE LINE TOOLS AND ACCESSORIES

Glove And Sleeve Bags	35
Isolating Link And Spiral Link Sticks	33
Rubber Insulating Blankets	33
Rubber Blanket Accessories	34
Shotgun Sticks	32
Universal and Switch Head Sticks	32

POLE LINE HARDWARE

Heavy Duty Banding	36
Hold Down Weights	37
Light Duty Banding	37
Pole Band System	36
Pole Line Suspension Clamps	38
Pole Staples	37

POLE SETTING AND GROUND MATERIALS

10k Drive Wrench Assembly	40-41
Anchor Buster	39
Anchor Rod Pulling Eye	39
Dirt Tarps	43
Pole Light Kit	39
Pole Puller	42
Pole Stand	43

RIGGING, STRINGING AND CABLE LAYING

2k, 3k, 4k Strap Hoists	48-49
Cable Laying Rollers	50-52
Distribution Stringing Blocks and Accessories	44-45
Guy Wire Dispenser	46
Hand Line Tools	47
Reel Lifter	47
Triplex Dispenser	46

IMPORTANT TECHNICAL INFORMATION

Cable Grip Safety Information	53
Lace Up Cable Grip Instructions	55
Single and Double Eye Cable Grip Instructions	54

⚠ WARNING

Cancer and Reproductive Harm www.P65Warnings.ca.gov

Some of the products in this catalogue are subject to Prop65 health warnings. For details, please contact us.

PLEASE NOTE: While every effort has been made to ensure accuracy of all content in this catalogue, please confirm with your Slingco contact any critical information before purchase.

Cable Grips and Accessories

High-strength grips, swivels, and accessories for stringing, trench cabling, and utility maintenance.



p5-17

CatchBlock

Two-rope catenary roller system enabling safe conductor recovery without accessing property or infrastructure beneath transmission lines.



p18-21

Conductor Support

Fiberglass Extension Arms for moving conductors to create working clearance in congested areas or temporary aid for replacing insulators and existing conductors.

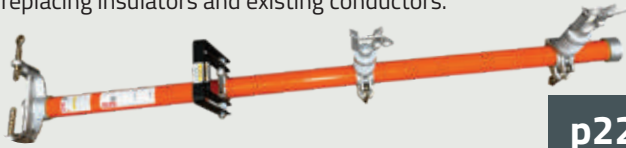

p22

Grounding and Jumper

Clamps for a wide variety of electrical grounding in utility and industrial settings. Jumpers to bypass work areas when equipment is under repair or being upgraded.

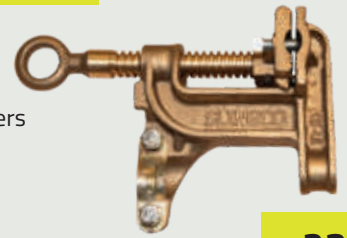

p23

Cutting Tools

Tough, ergonomic cutting tools designed for comfort, leverage, and dependable performance on the job.



p24-25

Crimping Tools

Hydraulic and Manual Crimpers that secure sleeves and lugs on ACSR and ACAR cables with utility-standard dies.



p26-27

Live Line Tools and Accessories

Hot Sticks, Isolating Link Sticks, and Safety Gear providing insulation and protection in high-voltage environments.



p28-31

Pole Line Hardware

Light and Heavy Duty banding systems that securely fasten cables and hardware to poles.



p32-34

Pole Setting and Ground Materials

Durable solutions for pole framing, anchoring, installation, and removal—built for safety and efficiency.



p35-39

Rigging and Stringing

Stringing Blocks, Brackets, Dispensers, and Hoists that streamline pulls and speed up installations.



p40-45

A TYPE - HIGH STRENGTH CABLE GRIP (HEAVY DUTY)



The strongest grip we produce; can be used for metal wire and synthetic rope pulls. Perfect for overhead transmission and distribution line pulling or any applications with heavy load ratings, e.g. gas, electric railroad, rigging lines and construction pulls. When pulling synthetic rope use a Slingco Feed Tube (see below) to make rope insertion a breeze. To avoid the effects of torsion a line pulling swivel that rotates under load should be used. Use A-Type Grips when pulling Guy or Static wire. Galvanised Steel and colour coded for ease of identification.

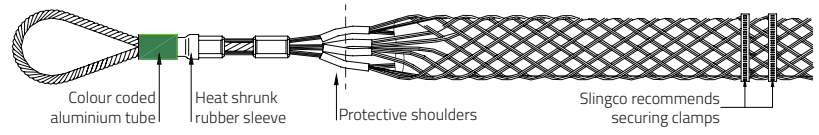

Slingco Part No	Colour Code	Rope Diameter Range		Conductor Diameter		Overall Length		Lattice Length		Approx. Break Load	
		in	mm	in	mm	in	mm	in	mm	lb	kg
ZCS1799	Black	0.25 - 0.65	6 - 16	0.19 - 0.40	5 - 10	38	965	26	665	7,000	3,180
ZCS3020	Purple	0.30 - 0.40	7.5 - 10	0.25 - 0.40	6 - 10	42	1,067	30	760	10,000	4,530
ZCS1800	Dark Green	0.50 - 0.90	13 - 23	0.38 - 0.63	9.7 - 16	52	1,326	38	966	14,000	6,360
ZCS3522	Grey	0.44 - 0.90	11 - 23	0.44 - 0.63	11 - 16	106	2,685	93	2,355	20,000	9,072
ZCS1801	Red	0.75 - 1.10	19 - 28	0.63 - 0.88	16 - 22	69	1,760	53	1,355	20,000	9,072
ZCS5543	Brown	0.75 - 1.10	19 - 28	0.63 - 0.88	16 - 22	81	2,060	62	1,579	30,700	13,925
ZCS1802	Blue	1.00 - 1.50	25 - 38	0.88 - 1.13	22 - 29	80	2,032	61	1,549	30,700	13,925
ZCS1803	Yellow	1.25 - 1.70	32 - 43	1.13 - 1.38	29 - 35	105	2,660	82	2,072	47,000	21,360
ZCS1804	Aluminium	1.50 - 2.10	38 - 53	1.38 - 1.90	35 - 50	119	3,020	89	2,265	67,000	30,455

Contact Slingco if you require high strength pulling grips for conductor sizes greater than 1.90"

FEED TUBE

Due to the tight construction of the A Type Cable Grip, we recommend using the Slingco Feed Tube when inserting cable or rope into the grips. For ease of use, our feed tubes are colour-coded to match the A Type Cable Grip.



Slingco part no.	Tube to fit rope diameter inches (mm)	Feed tube length inches (mm)	Matches Slingco Cable Grip part no.	Cable grip colour
FTU1890	0.25 - 0.65 (6 - 16)	29 (730)	ZCS1799, ZCS3020	Black
FTU1891	0.50 - 0.90 (13 - 23)	41 (1,041)	ZCS1800, ZCS3522	Dark green
FTU1892	0.75 - 1.10 (19 - 28)	53 (1,356)	ZCS1801	Red
FTU1893	1.00 - 1.50 (25 - 38)	69 (1,743)	ZCS1802	Blue
FTU1894	1.25 - 1.70 (32 - 43)	85 (2,156)	ZCS1803	Yellow
FTU1895	1.50 - 2.10 (38 - 53)	98 (2,498)	ZCS1804	Aluminium

MU TYPE - HIGH STRENGTH CABLE GRIP (HEAVY-MEDIUM DUTY)

This grip's multi-weave construction is ideal for heavy loads. MU Cable Grips are colour coded for ease of identification. Perfect for stringing overhead transmission and distribution lines and heavy-load pulls of any kind. Use with bare or insulated cable, conductor or wire. The flexible eye connects with Slingco Line Pulling Swivels for trouble free pulling applications. Recommend use of A-Type Grips when pulling Guy or Static wire. Made of Galvanised Steel.

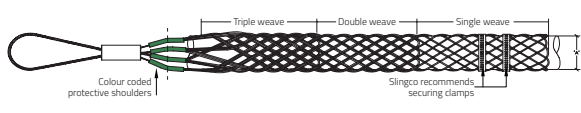

Slingco Part No	Colour Code	Range		Lattice Length		Approx. Break Load	
		in	mm	in	mm	lb	kg
ZCS1710	Dark Green	0.25 - 0.50	6 - 13	28	720	7,000	3,170
ZCS1711	Brown	0.50 - 0.75	13 - 19	39	978	10,500	4,760
ZCS1712	Light Blue	0.75 - 1.00	19 - 25	43	1,092	14,100	6,395
ZCS1713	Gold	1.00 - 1.25	25 - 32	58	1,470	25,000	11,340
ZCS1714	Black	1.25 - 1.50	32 - 38	51	1,291	31,000	14,065
ZCS1715	Red	1.50 - 1.75	38 - 44	68	1,739	31,000	14,065
ZCS1716	Dark Blue	1.75 - 2.25	44 - 57	69	1,747	49,000	22,230
ZCS1750	Yellow	2.00 - 2.50	51 - 63	54	1,370	49,000	22,230
ZCS1751	Orange	2.50 - 3.00	63 - 76	52	1,311	49,000	22,230
ZCS1752	Aluminium	3.00 - 3.50	76 - 89	53	1,342	49,000	22,230
ZCS1753	Light Green	3.50 - 4.00	89 - 102	53	1,351	49,000	22,230

LINE PULLING SWIVEL - BRIGHT ZINC PLATED STEEL

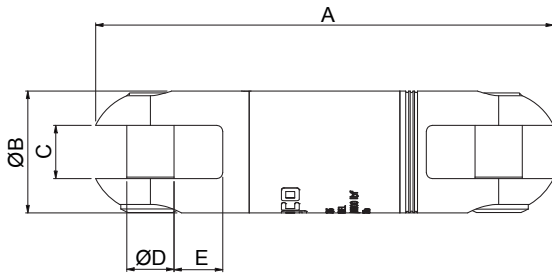

Swivels designed for use in stringing high tension wires for electrical transmission and distribution. Swivels are important in pulling when the lines develop torsion during installation. Swivels will release torque and prevent it from reaching dangerous levels, which can cause damage to the cable. All swivels are stringently quality tested and inspected to ensure optimum performance and reliability.

Slingco part no.	Safe working load (lb)		A (in)	Ø B (in)	C (in)	Ø D Pin (in)	E Recess (in)	Weight (lb)
	3:1 FOS	5:1 FOS						
ZSW2091	2,250	1,350	3.39	0.87	0.39	0.31	0.39	0.43
ZSW2092	3,500	2,100	3.98	0.98	0.43	0.39	0.43	0.56
ZSW2093	5,000	3,000	4.96	1.26	0.55	0.39	0.55	1.13
ZSW2094	7,000	4,200	5.22	1.38	0.55	0.5	0.54	1.44
ZSW2096	10,000	6,000	6.1	1.62	0.71	0.63	0.65	2.35
ZSW2097	15,000	9,000	7.34	2.09	0.79	0.71	0.83	4.59

Note: 3:1 factor of safety and 5:1 factor of safety provided for reference only

Swivel and MU & R Type Cable Grip match-up

Approx. breaking strength of cable grip (lb)	MU & R Type cable grip colour code	Size range O.D. (in)	Recommended swivel	Safe working load of swivel (lb) 3:1 FOS	Revolving Eye	Flexible Eye MU
7,000	Dark green	0.25 - 0.50	ZSW2092	3,500	ZCS2177	ZCS1710
10,500	Brown	0.50 - 0.75	ZSW2093	5,000	ZCS2178	ZCS1711
14,100	Light blue	0.75 - 1.00	ZSW2093	5,000	ZCS2179	ZCS1712
25,000	Gold	1.00 - 1.25	ZSW2096	10,000	ZCS2180	ZCS1713
31,000	Black	1.25 - 1.50	ZSW2096	10,000	ZCS2181	ZCS1714
31,000	Red	1.50 - 1.75	ZSW2096	10,000	ZCS2182	ZCS1715
43,000-48,000	Dark blue	1.75 - 2.25	ZSW2097	15,000	ZCS2183	ZCS1716

Note: The above is intended as a rough guide. The recommended working load should be determined by the competent person(s) using the cable grip and/or Slingco swivel.

LINE PULLING SWIVEL - GALVANISED

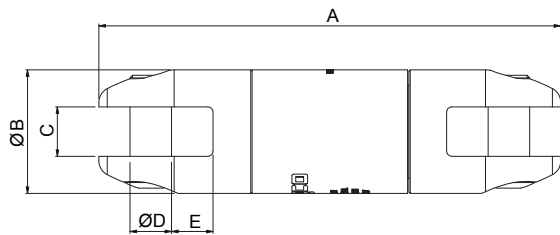

Slingco Line Swivels are designed to the highest specifications for underground and overhead pulling applications. All swivels are stringently quality tested and inspected to ensure optimum reliability and performance.

Slingco part no.	Safe working load (lb)		A Length (in)	Ø B (in)	C (in)	Ø D Pin (in)	E Recess (in)	Weight (lb)
	3:1 FOS	5:1 FOS						
ZSW2649	4,000	2,400	4.74	1.26	0.61	0.37	0.52	1.01
ZSW2929	8,000	4,800	5.38	1.5	0.63	0.43	0.61	1.75
ZSW6122	10,000	6,000	7	1.87	0.75	0.63	0.63	3.72
ZSW6123	16,000	9,600	10.2	2.44	1	0.87	1.12	9.19
ZSW2857	30,000	18,000	11.13	2.5	1	0.87	1.13	10.44

Note: 3:1 factor of safety and 5:1 factor of safety provided for reference only

Swivel or Connector Model	ZSW2091 ZSW6554	ZSW2092	ZSW2093 ZSW6555	ZSW2094	ZSW6122	ZSW2096	ZSW2097	ZSW2929	ZSW2649	ZSW2857	ZSW6123	ZSW6556	ZSW6557 ZSW6558 ZSW6559 ZSW6560
Replacement Pin (HEX)	SWI2859	SWI2810	SWI2339	SWI2341	SWI2343	SWI4079	SWI2344	SWI2801	SWI2648	SWI2748	SWI5184	SWI5309	SWI5310

SAFETY NOTE: All Slingco Line Pulling Swivels are designed for straight line pulling and will not support side loads as would be encountered traveling over a bull wheel. Swivel selection should be based on pulling line diameter, grip size, opening dimensions, pin sizes, working load, and sheave groove diameter. Swivels are not designed for general lifting.

ULTRA-FLEX SINGLE EYE DOUBLE WEAVE NON-METALLIC CABLE GRIP



Slingco Single Eye Double Weave Non-Metallic Aramid Grips are perfect for pulling cables through conduit especially when using lube. These grips are flexible and easy to install and handle. Colour coded for quick identification of cable ranges.

Slingco Part No	Range		Colour code	Approx. Break Load	
	in	mm		lb	kg
ULTRA-FLEX SINGLE EYE DOUBLE WEAVE NON-METALLIC CABLE GRIP					
ZCS09336	0.63 - 0.75	16 - 19	Yellow	5,000	2,267
ZCS09337	0.75 - 1.00	19 - 25	Red	6,000	2,721
ZCS09338	1.00 - 1.25	25 - 32	Blue	6,000	2,721
ZCS09339	1.25 - 1.50	32 - 38	White	6,000	2,721

CONNECTORS: 90°, ROPE TO ROPE, ROPE TO SWIVEL

Use to connect rope, swivels and other objects. With high strength pins and smooth rollers you can safely connect rope without fear of fraying or damage. Use the convenient 90° Connectors to link wire and other non-rope items. Connectors have high strength hex pins. The Rope to Rope connector has two rollers to protect rope from becoming frayed.

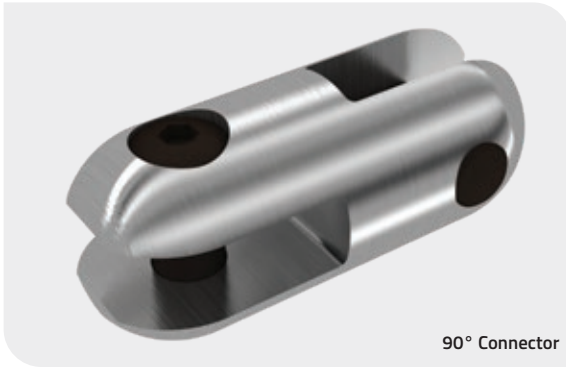

90° Connector

90° Connector

Slingco part no.	Safe working load lb (kg)	A in (mm)	B in (mm)	C in (mm)	D in (mm)	E in (mm)	Weight lb (kg)
ZSW6554	2,500 (1,134)	0.875 (22)	0.375 (9.6)	0.314 (8)	2.126 (54)	0.969 (24.6)	0.17 (0.08)
ZSW6555	5,000 (2,240)	1.25 (31.75)	0.53 (13.5)	0.393 (10)	2.875 (73)	1.28 (32.5)	0.46 (0.21)
ZSW6556	9,000 (4,030)	1.5 (38.1)	0.591 (15)	0.492 (12.5)	3.386 (86)	1.563 (39.7)	0.73 (0.33)
ZSW6557	15,000 (6,800)	2 (50.8)	0.787 (20)	0.71 (18)	4.567 (116)	2.142 (54.4)	2 (0.91)

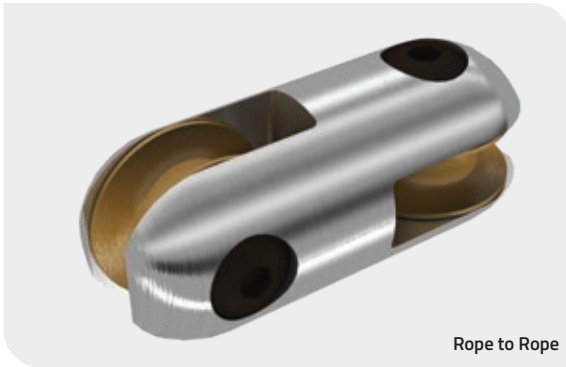
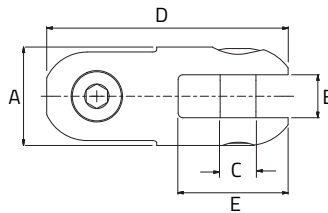

Rope to Rope

Rope to Rope Connector

Slingco part no.	Safe working load lb (kg)	A in (mm)	B in (mm)	C in (mm)	D in (mm)	E in (mm)	Weight lb (kg)
ZSW6558	15,000 (6,800)	2 (50.8)	0.94 (24)	0.709 (18)	5.512 (140)	2.52 (64)	2.17 (1.23)

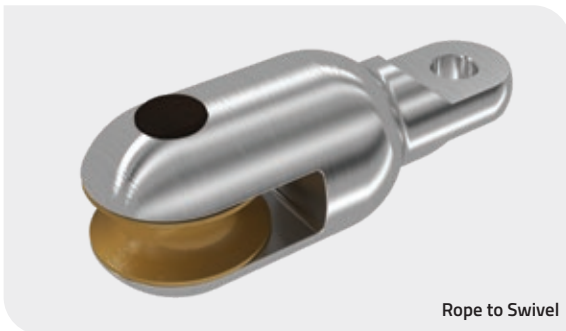
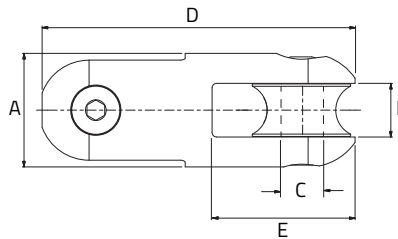

Rope to Swivel

Rope to Swivel Connector

Slingco part no.	Safe working load lb (kg)	A in (mm)	B in (mm)	C in (mm)	D in (mm)	E in (mm)	F in (mm)	G in (mm)	Weight lb (kg)
ZSW6559	7,000 (3,170)	2 (50.8)	0.94 (24)	0.71 (18)	5.31 (135)	2.52 (64)	0.5 (12.7)	0.53 (13.5)	2.09 (0.95)
ZSW6560	15,000 (6,800)	2 (50.8)	0.94 (24)	0.71 (18)	5.31 (135)	2.52 (64)	0.656 (16.7)	0.71 (18)	2.54 (1.15)

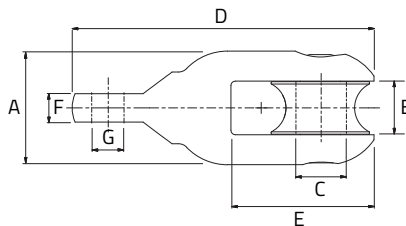

ANTI ROTATIONAL DEVICE



The device prevents the cable from twisting as it travels over pulling blocks. Left uncontrolled, the optical cable's delicate glass fibres could be permanently damaged during installation.

- Stops cables from twisting as they pass over pulling blocks
- For use with Fibre Optic and OPGW cable
- Prevents irreparable damage to delicate fibre optics caused by cable twists during installation
- The ARD has weighted attachments that hang down while stringing, keeping the ARD vertical to stop cable rotation
- ARD attachments collapse in line, enabling them to travel easily over pulling blocks
- The ARD includes one 5,000 lb swivel attached to the head of the device

Specification	
Slingco Part No.	ZAD3799
Overall Length	29' Approx.
Working load (@3:1 Safety Factor)	5,000 lbs
Length of Attachments	8' Approx.
Weight of Attachment	14 lbs each Approx.

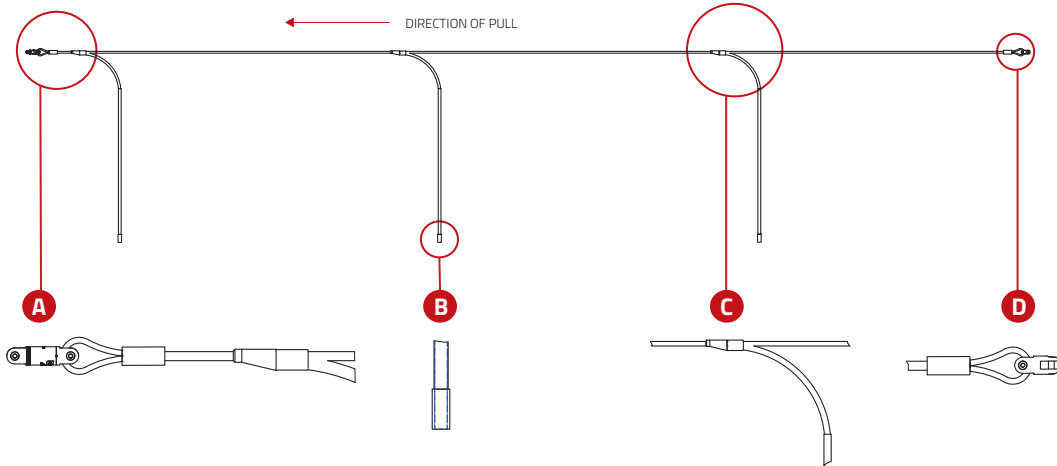

R TYPE - ROTATING EYE MULTI-WEAVE CABLE GRIP (UNDERGROUND)

Like the MU Type, the Rotating Eye Cable Grip has a triple weave construction and is colour coded for ease of identification. The steel forged revolving head is ideal for connecting to Slingco Swivels. Warning: The Slingco Rotating Eye Cable Grip does not revolve under load and does not replace the use of a line swivel. Please see page 6 for swivel and grip match-up and safety and technical information. Made of Galvanised Steel.

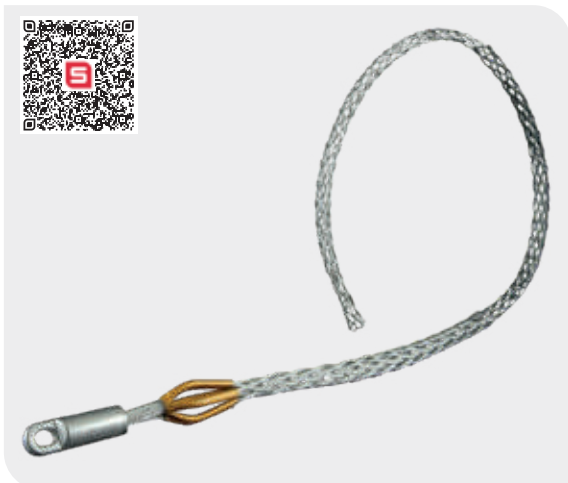

Slingco Part No	Colour Code	Range		Lattice Length		Approx. Break Load	
		in	mm	in	mm	lb	kg
ZCS2177	Dark Green	0.25 - 0.50	6 - 12	28	720	7,000	3,175
ZCS2178	Brown	0.50 - 0.75	12 - 19	39	978	10,500	4,760
ZCS2179	Light Blue	0.75 - 1.00	19 - 25	47	1,199	14,100	6,395
ZCS2180	Gold	1.00 - 1.25	25 - 32	60	1,529	25,000	11,340
ZCS2181	Black	1.25 - 1.50	32 - 38	51	1,289	31,000	14,061
ZCS2182	Red	1.50 - 1.75	38 - 44	73	1,860	31,000	14,061
ZCS2183	Dark blue	1.75 - 2.25	44 - 57	69	1,747	48,000	21,772
ZCS2779	Yellow	2.00 - 2.50	51 - 63	54	1,370	48,000	21,772
ZCS2780	Orange	2.50 - 3.00	63 - 76	52	1,311	48,000	21,772
ZCS2781	Aluminium	3.00 - 3.50	76 - 89	53	1,342	48,000	21,772
ZCS2782	Light Green	3.50 - 4.00	89 - 102	53	1,351	48,000	21,772

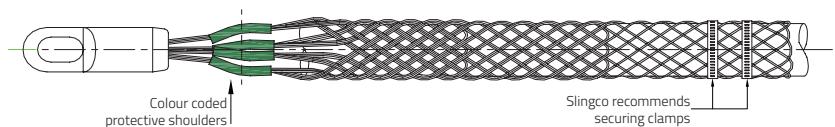

RT TYPE - ROTATING EYE DOUBLE WEAVE CABLE GRIP (UNDERGROUND)



Double weave construction for medium to heavy pulling applications in underground installations. Additionally its steel forged revolving head is ideal for connecting to Slingco Swivels. Warning: The Slingco RT Type Rotating Eye Cable Grip does not revolve under load. The rotating eye does not replace the need for a swivel. See page 6 for swivel and grip match-up and safety and technical information.

Slingco Part No	Range		Lattice Length		Approx. Break Load	
	in	mm	in	mm	lb	kg
SHORT LENGTH - GALVANISED STEEL						
ZCS2734	0.50 - 0.62	13 - 16	12	300	5,600	2,540
ZCS2735	0.62 - 0.75	16 - 19	12	305	6,800	3,084
ZCS2736	0.75 - 1.00	19 - 25	19	474	6,800	3,084
ZCS2738	1.00 - 1.50	25 - 38	22	549	12,800	5,806
ZCS2739	1.50 - 2.00	38 - 51	22	552	16,400	7,439
ZCS2740	2.00 - 2.50	51 - 63	23	587	27,200	12,338
ZCS2741	2.50 - 3.00	63 - 76	25	642	33,000	14,969
ZCS2742	3.00 - 3.50	76 - 89	29	731	43,000	19,504
ZCS2743	3.50 - 4.00	89 - 102	34	854	43,000	19,504
ZCS2744	4.00 - 4.50	102 - 114	33	826	43,000	19,504
STANDARD - LONGER LENGTH - GALVANISED STEEL						
ZCS2745	0.50 - 0.62	13 - 16	16	405	5,600	2,540
ZCS2746	0.62 - 0.75	16 - 19	17	436	6,800	3,084
ZCS2747	0.75 - 1.00	19 - 25	30	765	6,800	3,084
ZCS2748	1.00 - 1.50	25 - 38	32	812	16,400	7,439
ZCS2749	1.50 - 2.00	38 - 51	30	747	16,400	7,439
ZCS2750	2.00 - 2.50	51 - 63	29	740	27,200	12,338
ZCS2751	2.50 - 3.00	63 - 76	35	893	33,000	14,969
ZCS2752	3.00 - 3.50	76 - 89	40	1,005	41,000	18,597
ZCS2753	3.50 - 4.00	89 - 102	40	1,014	43,000	19,504
ZCS2754	4.00 - 4.50	102 - 114	37	947	48,000	21,772
ZCS2755	4.50 - 5.00	114 - 127	53	1,350	48,000	21,772
ZCS2756	5.00 - 6.00	127 - 153	54	1,361	48,000	21,772
ZCS2757	6.00 - 7.00	153 - 178	62	1,563	48,000	21,772

FAST BANDING: Pre-Looped Bands for quickly securing grips and other simple banding applications

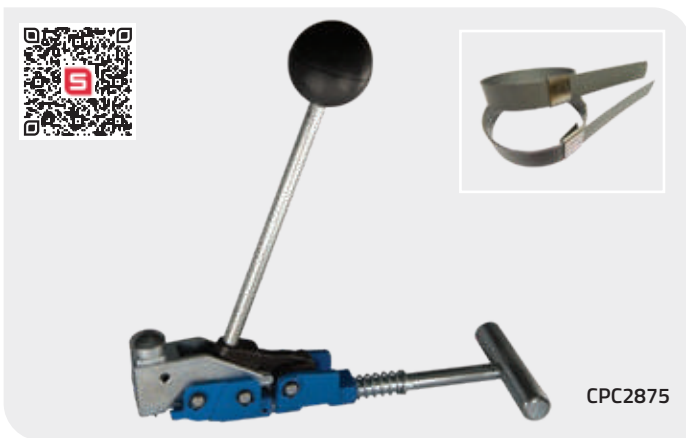

Use pre-looped punch style bands to quickly and securely band cable grips, hoses or other cylindrical items.

The bands are pre-looped through the buckle to slide over the end of the item being banded. Just tighten the band using the Slingco Punch Banding Tool then, when the band is tight, just punch the head of the tool and snip off the extra banding. Simple!

Note: Slingco recommends double banding the ends of cable grips.

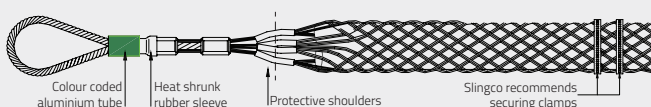

Banding tool					
Description	Slingco part no.				
Standard punch-style banding tool.	CPC2875				
Bands Pre-Looped					
Width	Thickness	Loop diameter	Pack quantity	Slingco part no.	
3/8"	0.025"	13/16"	100/box	CPC2876	
5/8"	0.030"	1"	100/box	CPC2880	
5/8"	0.030"	1.5"	100/box	CPC2879	
5/8"	0.030"	2.0"	100/box	CPC2878	
5/8"	0.030"	2.5"	50/box	CPC2877	
5/8"	0.030"	3.0"	50/box	CPC8532	
Open End Band – 201 SS					
Width	Thickness	Length	Loop diameter	Pack quantity	Slingco part no.
5/8"	0.030"	24"	6" Single Wrap 3" Double Wrap	50/box	CPC08596

The sizes opposite refer to the inner loop diameter of the band. Select the size that will comfortably fit over the item being banded.

Open End Band – non pre-looped 201 SS 5/8" wide band with attached buckle. Includes punch style buckle. Use as single loop for larger diameter or double looped for smaller diameters and added strength. Maximum diameter for single or double loops is listed.

SINGLE EYE CLOSED MESH CABLE SUPPORT GRIP

Slingco closed mesh support grip in 304 Stainless Steel. Closed mesh for when end of cable is available.



Slingco Part No	Range		Lattice Length		Approx. Break Load	
	in	mm	in	mm	lb	kg
ZCS1893	0.50 - 0.63	13 - 16	10	247	570	255
ZCS1894	0.63 - 0.75	16 - 19	10	247	890	400
ZCS1895	0.75 - 1.00	19 - 25	14	345	1,040	470
ZCS1896	1.00 - 1.25	25 - 32	14	345	1,700	770
ZCS1897	1.25 - 1.50	32 - 38	15	382	1,700	770
ZCS1898	1.50 - 1.75	38 - 44	18	450	1,700	770
ZCS1899	1.75 - 2.00	44 - 51	19	490	2,300	1,045
ZCS1900	2.00 - 2.50	51 - 64	23	574	3,400	1,540
ZCS1901	2.50 - 3.00	64 - 76	25	638	3,400	1,540
ZCS1902	3.00 - 3.50	76 - 89	29	741	5,000	2,265
ZCS1903	3.50 - 4.00	89 - 102	35	880	5,000	2,265
ZCS5032	3.50 - 4.50	89 - 114	46	1,168	5,000	2,265

SINGLE EYE SPLIT MESH LACE CLOSING CABLE SUPPORT GRIP

In 304 Stainless Steel. Split mesh is for when end of cable is not available.



Slingco Part No	Range		Lattice Length		Approx. Break Load	
	in	mm	in	mm	lb	kg
ZCS1904	0.50 - 0.63	13 - 16	10	247	530	240
ZCS1905	0.63 - 0.75	16 - 19	10	247	790	355
ZCS1906	0.75 - 1.00	19 - 25	14	345	1,020	460
ZCS1907	1.00 - 1.25	25 - 32	14	344	1,610	730
ZCS1908	1.25 - 1.50	32 - 38	15	382	1,610	730
ZCS1909	1.50 - 1.75	38 - 44	18	450	1,610	730
ZCS1910	1.75 - 2.00	44 - 51	19	490	2,150	975
ZCS1911	2.00 - 2.50	51 - 63	23	574	3,260	1,480
ZCS1912	2.50 - 3.00	63 - 76	25	638	3,260	1,480
ZCS1913	3.00 - 3.50	76 - 89	29	742	4,900	2,220
ZCS1914	3.50 - 4.00	89 - 102	35	880	4,900	2,220

SINGLE EYE SPLIT MESH ROD CLOSING CABLE SUPPORT GRIP

Similar to the Lace Up Grip, in 304 Stainless Steel, but in this design it is closed by inserting a metal rod down the length of the grip. For when end of cable is not available.

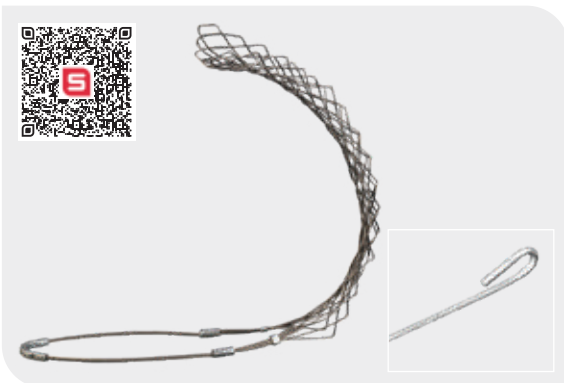

Slingco Part No	Range		Lattice Length		Approx. Break Load	
	in	mm	in	mm	lb	kg
ZCS2362	0.50 - 0.63	13 - 16	10	247	567	255
ZCS2363	0.63 - 0.75	16 - 19	10	247	890	400
ZCS2162	0.75 - 1.00	19 - 25	13	331	1,040	470
ZCS2163	1.00 - 1.25	25 - 31	14	343	1,700	770
ZCS2164	1.25 - 1.50	31 - 38	15	382	1,700	770
ZCS2165	1.50 - 1.75	38 - 44	16	419	2,300	1,045
ZCS2166	1.75 - 2.00	44 - 51	20	509	3,400	1,540
ZCS2167	2.00 - 2.50	51 - 63	21	535	3,400	1,540
ZCS2168	2.50 - 3.00	63 - 76	24	611	5,000	2,265
ZCS2169	3.00 - 3.50	76 - 89	26	662	5,000	2,265
ZCS2372	3.50 - 4.00	89 - 102	29	738	5,000	2,265

DOUBLE EYE CLOSED MESH CABLE SUPPORT GRIP

Double Eye Closed Mesh Support Grip in 304 Stainless Steel. Two eyes for two connect/support points. Closed mesh for when end of cable is available.



Slingco Part No	Range		Lattice Length		Approx. Break Load	
	in	mm	in	mm	lb	kg
ZCS2038	0.50 - 0.63	13 - 16	10	247	512	230
ZCS2039	0.63 - 0.75	16 - 19	10	247	740	335
ZCS2040	0.75 - 1.00	19 - 25	14	345	1,000	450
ZCS2041	1.00 - 1.25	25 - 32	14	344	1,540	695
ZCS2042	1.25 - 1.50	32 - 38	15	382	1,540	695
ZCS2043	1.50 - 1.75	38 - 44	18	450	2,010	910
ZCS2044	1.75 - 2.00	44 - 51	19	490	2,300	1,045
ZCS2045	2.00 - 2.50	51 - 63	23	574	3,230	1,465
ZCS2046	2.50 - 3.00	63 - 76	25	638	4,000	1,815
ZCS2047	3.00 - 3.50	76 - 89	29	741	4,000	1,815
ZCS2048	3.50 - 4.00	89 - 102	35	880	4,000	1,815
ZCS6404	4.00 - 4.50	102 - 114	30	762	4,000	1,815
ZCS6405	4.50 - 5.00	114 - 127	30	762	4,000	1,815
ZCS6406	5.00 - 5.50	127 - 140	30	762	4,000	1,815

DOUBLE EYE SPLIT MESH LACE CLOSING CABLE SUPPORT GRIP

Double Eye Split Mesh Lace Closing, in 304 Stainless Steel, for secure attachment and support where the cable end is not accessible.



Slingco Part No	Range		Lattice Length		Approx. Break Load	
	in	mm	in	mm	lb	kg
ZCS2998	0.50 - 0.63	13 - 16	10	254	530	240
ZCS2999	0.63 - 0.75	16 - 19	10	254	790	360
ZCS3000	0.75 - 1.00	19 - 25	14	345	1,020	460
ZCS3001	1.00 - 1.25	25 - 32	14	345	1,610	730
ZCS3002	1.25 - 1.50	32 - 38	15	381	1,610	730
ZCS3003	1.50 - 1.75	38 - 44	18	450	1,610	730
ZCS3004	1.75 - 2.00	44 - 51	19	482	2,150	975
ZCS3005	2.00 - 2.50	51 - 63	23	574	3,260	1,480
ZCS3006	2.50 - 3.00	63 - 76	25	638	3,260	1,480
ZCS3007	3.00 - 3.50	76 - 89	29	742	4,900	2,222
ZCS3008	3.50 - 4.00	89 - 102	35	880	4,900	2,222

DOUBLE EYE SPLIT MESH ROD CLOSING CABLE SUPPORT GRIP

Double Eye Split Mesh Rod Closing, in 304 Stainless Steel, for secure attachment and support where the cable end is not accessible.



Slingco Part No	Range		Lattice Length		Approx. Break Load	
	in	mm	in	mm	lb	kg
ZCS3009	0.50 - 0.63	13 - 16	9	216	790	355
ZCS3010	0.63 - 0.75	16 - 19	9	216	790	355
ZCS3011	0.75 - 1.00	19 - 25	11	267	1,020	460
ZCS3012	1.00 - 1.25	25 - 32	12	317	1,610	730
ZCS3013	1.25 - 1.50	32 - 38	14	368	1,610	730
ZCS3014	1.50 - 1.75	38 - 44	16	394	1,610	730
ZCS3015	1.75 - 2.00	44 - 51	16	419	2,150	975
ZCS3016	2.00 - 2.50	51 - 63	19	495	3,260	1,480
ZCS3017	2.50 - 3.00	63 - 76	21	546	3,260	1,480
ZCS3018	3.00 - 3.50	76 - 89	24	597	5,750	2,600
ZCS3019	3.50 - 4.00	89 - 102	26	648	5,750	2,600

OFFSET EYE CLOSED MESH CABLE SUPPORT GRIP

This Offset Eye Grip, in 304 Stainless Steel, is designed to support cable as it hangs vertically or horizontally when the end of the cable is available.

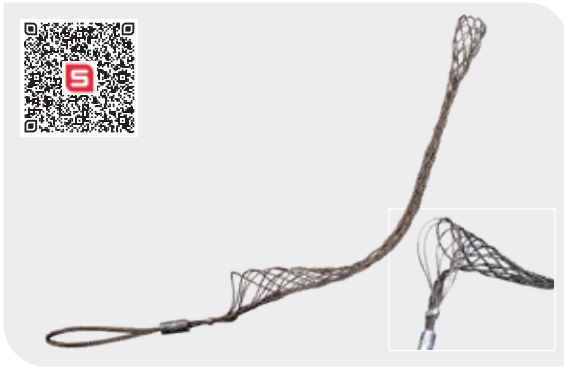

Slingco Part No	Range		Lattice Length		Approx. Break Load	
	in	mm	in	mm	lb	kg
ZCS1915	0.50 - 0.63	13 - 16	10	247	512	230
ZCS1916	0.63 - 0.75	16 - 19	10	247	740	335
ZCS1917	0.75 - 1.00	19 - 25	14	345	1,000	450
ZCS1918	1.00 - 1.25	25 - 32	14	345	1,540	695
ZCS1919	1.25 - 1.50	32 - 38	16	415	1,540	695
ZCS1920	1.50 - 1.75	38 - 44	18	450	2,010	910
ZCS1921	1.75 - 2.00	44 - 51	21	530	2,010	910
ZCS1922	2.00 - 2.50	51 - 63	23	574	3,230	1,465
ZCS1923	2.50 - 3.00	63 - 76	31	779	3,230	1,815
ZCS1924	3.00 - 3.50	76 - 89	36	915	4,000	1,815
ZCS1925	3.50 - 4.00	89 - 102	41	1,050	4,000	1,815
ZCS6408	4.00 - 4.50	102 - 114	30	762	4,000	1,815
ZCS6409	4.50 - 5.00	114 - 127	30	762	4,000	1,815
ZCS6410	5.00 - 5.50	127 - 140	30	762	4,000	1,815

OFFSET EYE SPLIT MESH LACE CLOSING CABLE SUPPORT GRIP

This grip, in 304 Stainless Steel, is ideal for several support points along the same cable when the cable ends are not accessible.

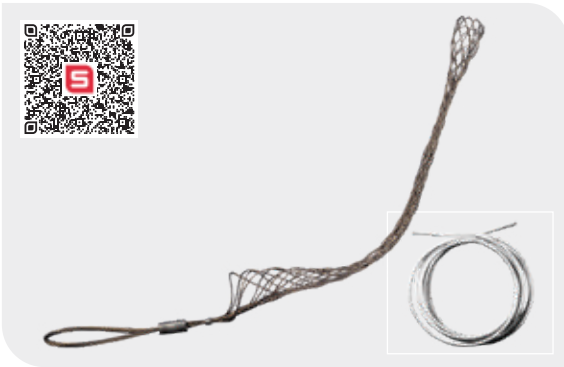

Slingco Part No	Range		Lattice Length		Approx. Break Load	
	in	mm	in	mm	lb	kg
ZCS1926	0.50 - 0.63	13 - 16	10	249	500	225
ZCS1927	0.63 - 0.75	16 - 19	10	249	750	340
ZCS1928	0.75 - 1.00	19 - 25	14	345	950	430
ZCS1929	1.00 - 1.25	25 - 32	14	345	1,500	680
ZCS1930	1.25 - 1.50	32 - 38	16	415	1,500	680
ZCS1931	1.50 - 1.75	38 - 44	18	450	1,500	680
ZCS1932	1.75 - 2.00	44 - 51	21	530	2,000	905
ZCS1933	2.00 - 2.50	51 - 63	23	574	2,150	975
ZCS1934	2.50 - 3.00	63 - 76	25	638	2,150	975
ZCS1935	3.00 - 3.50	76 - 89	29	742	3,800	1,720
ZCS1936	3.50 - 4.00	89 - 102	35	880	3,800	1,720

OFFSET EYE SPLIT MESH ROD CLOSING CABLE SUPPORT GRIP

Ideal for several support points along the same cable when the cable ends are not accessible. Made from 304 Stainless Steel.

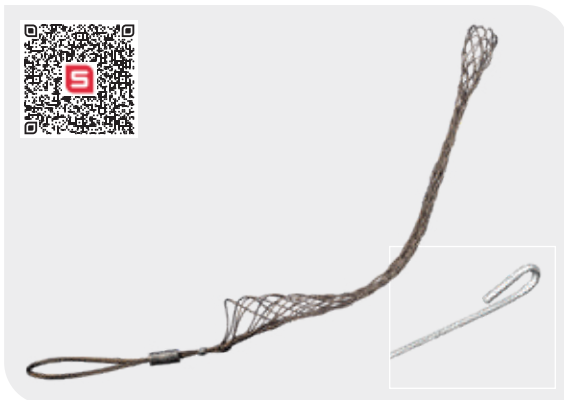

Slingco Part No	Range		Lattice Length		Approx. Break Load	
	in	mm	in	mm	lb	kg
ZCS3031	0.50 - 0.63	13 - 16	7	178	500	225
ZCS3032	0.63 - 0.75	16 - 19	9	229	750	340
ZCS3033	0.75 - 1.00	19 - 25	10	254	950	430
ZCS3034	1.00 - 1.25	25 - 32	12	305	1,500	680
ZCS3035	1.25 - 1.50	32 - 38	14	359	1,500	680
ZCS3036	1.50 - 1.75	38 - 44	15	381	1,500	680
ZCS3037	1.75 - 2.00	44 - 51	16	406	2,000	905
ZCS3038	2.00 - 2.50	51 - 63	19	483	3,100	975
ZCS3039	2.50 - 3.00	63 - 76	20	508	3,100	975
ZCS3040	3.00 - 3.50	76 - 89	21	533	4,300	1,720
ZCS3041	3.50 - 4.00	89 - 102	21	533	4,300	1,720

UNIVERSAL EYE CLOSED MESH CABLE SUPPORT GRIP

Fitted with an adjustable eye for easy and secure attachment, where the end of the cable can be inserted in to the support grip. Made from 304 Stainless Steel.



Slingco Part No	Range		Lattice Length		Approx. Break Load	
	in	mm	in	mm	lb	kg
ZCS2664	0.50 - 0.63	13 - 16	10	254	530	240
ZCS4272	0.58 - 0.68	14.7 - 17.3	12	305	1,050	469
ZCS2665	0.63 - 0.75	16 - 19	10	254	790	360
ZCS2666	0.75 - 1.00	19 - 25	14	345	1,020	460
ZCS4273	0.75 - 0.87	19 - 22.1	13	330	1,390	620
ZCS4274	0.87 - 1.00	22.1 - 25.4	14	355	1,790	799
ZCS2667	1.00 - 1.25	25 - 32	14	355	1,610	730
ZCS2324	1.25 - 1.50	32 - 38	15	381	1,610	730
ZCS2668	1.50 - 1.75	38 - 44	18	450	1,610	730
ZCS2669	1.75 - 2.00	44 - 51	19	483	2,150	975
ZCS2670	2.00 - 2.50	51 - 63	23	574	3,260	1,480
ZCS2671	2.50 - 3.00	63 - 76	25	638	3,260	1,480

UNIVERSAL EYE SPLIT MESH LACE CLOSING CABLE SUPPORT GRIP

Fitted with an adjustable eye for easy and secure attachment, where the end of the cable is not accessible. Made from 304 Stainless Steel.



Slingco Part No	Range		Lattice Length		Approx. Break Load	
	in	mm	in	mm	lb	kg
ZCS2672	0.50 - 0.63	13 - 16	10	254	530	240
ZCS2673	0.63 - 0.75	16 - 19	10	254	790	360
ZCS2674	0.75 - 1.00	19 - 25	14	345	1,020	460
ZCS2675	1.00 - 1.25	25 - 32	14	355	1,610	730
ZCS2676	1.25 - 1.50	32 - 38	15	381	1,610	730
ZCS2677	1.50 - 1.75	38 - 44	17	432	1,610	730
ZCS2678	1.75 - 2.00	44 - 51	19	483	2,150	975
ZCS2679	2.00 - 2.50	51 - 63	21	533	3,260	1,480
ZCS2680	2.50 - 3.00	63 - 76	23	584	3,260	1,480
ZCS2681	3.00 - 3.50	76 - 89	25	635	4,900	2,222
ZCS2682	3.50 - 4.00	89 - 102	27	686	4,900	2,222

UNIVERSAL EYE SPLIT MESH ROD CLOSING CABLE SUPPORT GRIP

Fitted with an adjustable eye for easy and secure attachment, where the end of the cable is not accessible. Made from 304 Stainless Steel.

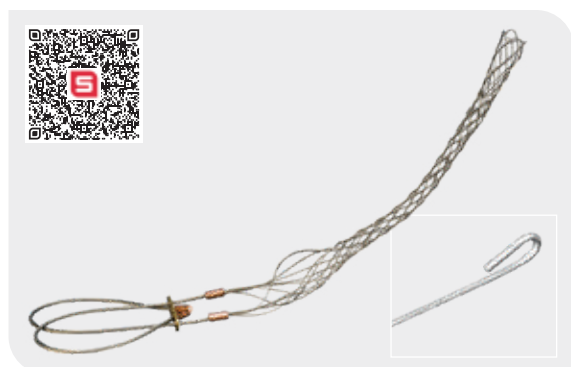

Slingco Part No	Range		Lattice Length		Approx. Break Load	
	in	mm	in	mm	lbs	kg
ZCS2683	0.50 - 0.63	12 - 16	9	216	530	240
ZCS2684	0.63 - 0.75	16 - 19	9	216	790	360
ZCS2685	0.75 - 1.00	19 - 25	11	267	1,020	460
ZCS2686	1.00 - 1.25	25 - 32	13	317	1,610	730
ZCS2687	1.25 - 1.50	32 - 38	15	368	1,610	730
ZCS2688	1.50 - 1.75	38 - 44	16	394	1,610	730

Heavy Duty Support Grips made from Stainless Steel are perfect for supporting heavier cable, conduit, or any other cylindrical object. Often used by Utilities and Contractors to support cables transitioning from overhead to underground. One may support multiple cables in one grip. The overall diameter of the cable bundle should fit within the listed range.

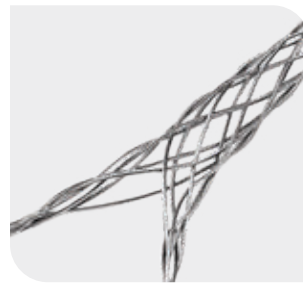

HEAVY DUTY SUPPORT GRIPS - SINGLE EYE

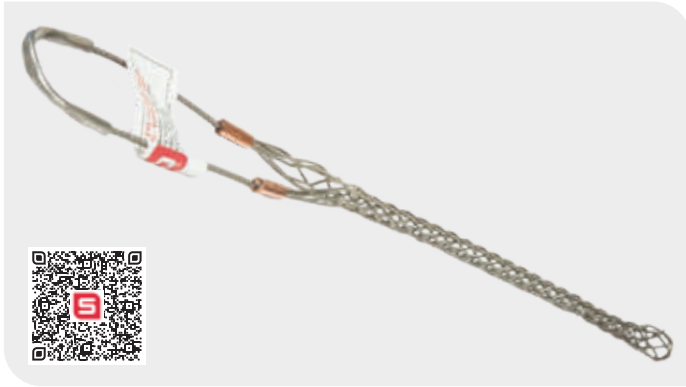

Slingco Part No.	Range		Lattice Length		Lattice Material	Approx. Break Load	
	in	mm	in	mm		lb	kg
ZCS7065	0.50 - 0.63	13 - 16	10	254	Stainless Steel	1,370	621
ZCS7066	0.63 - 0.75	16 - 19	11	267	Stainless Steel	2,080	944
ZCS7067	0.75 - 1.00	19 - 25	13	340	Stainless Steel	2,080	944
ZCS7068	1.00 - 1.25	25 - 32	15	381	Stainless Steel	2,680	1,216
ZCS7069	1.25 - 1.50	32 - 38	18	445	Stainless Steel	4,490	2,037
ZCS7070	1.50 - 1.75	38 - 44	19	495	Stainless Steel	4,490	2,037
ZCS7071	1.75 - 2.00	44 - 51	21	533	Stainless Steel	5,000	2,265
ZCS7072	2.00 - 2.50	51 - 63	21	546	Stainless Steel	8,940	4,056
ZCS7073	2.50 - 3.00	63 - 76	23	572	Stainless Steel	8,940	4,056
ZCS7074	3.00 - 3.50	76 - 89	27	686	Stainless Steel	10,250	4,649
ZCS7075	3.50 - 4.00	89 - 102	32	820	Stainless Steel	10,250	4,649

HEAVY DUTY SUPPORT GRIPS - SINGLE EYE LACE-UP

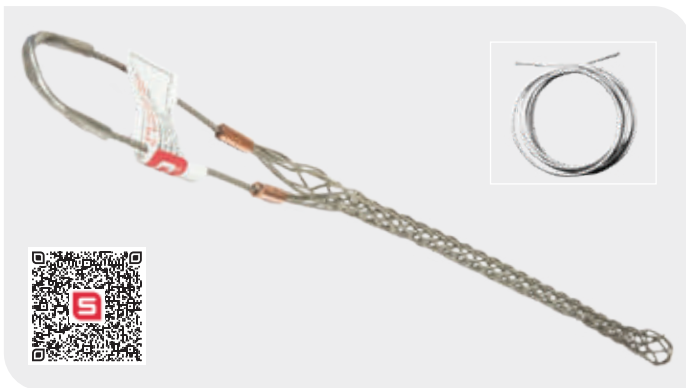

Slingco Part No.	Range		Lattice Length		Lattice Material	Approx. Break Load	
	in	mm	in	mm		lb	kg
ZCS6907	0.50 - 0.63	13 - 16	11	279	316 SS	1,370	621
ZCS6908	0.63 - 0.75	16 - 19	13	340	316 SS	2,080	944
ZCS6909	0.75 - 1.00	19 - 25	13	340	316 SS	2,080	944
ZCS6910	1.00 - 1.25	25 - 32	13	340	316 SS	2,670	1,211
ZCS6911	1.25 - 1.50	32 - 38	17	430	316 SS	4,490	2,037
ZCS6912	1.50 - 1.75	38 - 44	19	470	316 SS	4,490	2,037
ZCS6913	1.75 - 2.00	44 - 51	23	572	316 SS	5,000	2,265
ZCS6914	2.00 - 2.50	51 - 63	23	572	316 SS	8,940	4,056
ZCS6915	2.50 - 3.00	63 - 76	25	635	316 SS	8,940	4,056
ZCS6916	3.00 - 3.50	76 - 89	29	724	316 SS	13,420	6,089
ZCS6917	3.50 - 4.00	89 - 102	29	724	316 SS	13,420	6,089

HEAVY DUTY SUPPORT GRIPS - SINGLE EYE ROD CLOSING

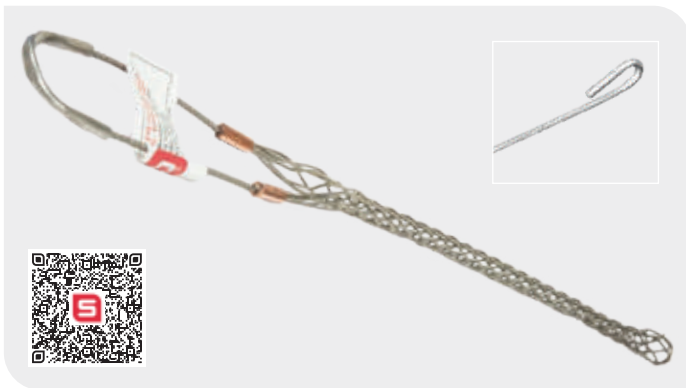

Slingco Part No.	Range		Lattice Length		Lattice Material	Approx. Break Load	
	in	mm	in	mm		lb	kg
ZCS7076	0.50 - 0.63	13 - 16	11	279	304 SS	1,370	621
ZCS7077	0.63 - 0.75	16 - 19	12	305	304 SS	2,080	944
ZCS7078	0.75 - 1.00	19 - 25	14	356	304 SS	2,080	944
ZCS7079	1.00 - 1.25	25 - 32	15	381	304 SS	2,680	1,215
ZCS7080	1.25 - 1.50	32 - 38	16	419	304 SS	4,490	2,037
ZCS7081	1.50 - 1.75	38 - 44	19	495	304 SS	4,490	2,037
ZCS7082	1.75 - 2.00	44 - 51	21	533	304 SS	5,000	2,265
ZCS7083	2.00 - 2.50	51 - 63	26	660	304 SS	8,940	4,056
ZCS7084	2.50 - 3.00	63 - 76	25	623	304 SS	8,940	4,056
ZCS7085	3.00 - 3.50	76 - 89	27	686	304 SS	13,420	6,089
ZCS7086	3.50 - 4.00	89 - 102	36	914	304 SS	13,420	6,089

HEAVY DUTY SUPPORT GRIPS - DOUBLE EYE



Slingco Part No.	Range		Lattice Length		Lattice Material	Approx. Break Load	
	in	mm	in	mm		lb	kg
ZCS3057	0.50 - 0.63	13 - 16	12	303	316 SS	1,370	621
ZCS3058	0.63 - 0.75	16 - 19	11	275	316 SS	2,080	944
ZCS3059	0.75 - 1.00	19 - 25	14	365	316 SS	2,080	944
ZCS3060	1.00 - 1.25	25 - 32	14	365	316 SS	2,670	1,211
ZCS7136	1.00 - 1.25	25 - 32	22	559	316 SS	2,670	1,211
ZCS7137	1.25 - 1.50	32 - 38	25	640	316 SS	4,490	2,037
ZCS7138	1.50 - 1.75	38 - 44	27	686	316 SS	4,490	2,037
ZCS7139	1.75 - 2.00	44 - 51	29	735	316 SS	5,000	2,265
ZCS3064	2.00 - 2.50	51 - 63	21	533	316 SS	8,940	4,056
ZCS7140	2.00 - 2.50	51 - 63	28	705	316 SS	8,940	4,056
ZCS3065	2.50 - 3.00	63 - 76	25	623	316 SS	8,940	4,056
ZCS7141	2.50 - 3.00	63 - 76	30	762	316 SS	8,940	4,056
ZCS7142	3.00 - 3.50	76 - 89	34	864	316 SS	12,000	5,445
ZCS7143	3.50 - 4.00	89 - 102	38	965	316 SS	12,000	5,445
ZCS7144	4.00 - 4.50	102 - 114	42	1,066	316 SS	12,000	5,445
ZCS7145	4.50 - 5.00	114 - 127	42	1,066	316 SS	12,000	5,445

HEAVY DUTY SUPPORT GRIPS - DOUBLE EYE LACE-UP



Slingco Part No.	Range		Lattice Length		Lattice Material	Approx. Break Load	
	in	mm	in	mm		lb	kg
ZCS7087	0.50 - 0.63	13 - 16	11	277	316 SS	1,370	621
ZCS7088	0.63 - 0.75	16 - 19	12	309	316 SS	2,080	944
ZCS7089	0.75 - 1.00	19 - 25	13	332	316 SS	2,080	944
ZCS7090	1.00 - 1.25	25 - 32	14	350	316 SS	2,670	1,211
ZCS7091	1.25 - 1.50	32 - 38	16	417	316 SS	4,490	2,037
ZCS7092	1.50 - 1.75	38 - 44	19	490	316 SS	4,490	2,037
ZCS7093	1.75 - 2.00	44 - 51	23	585	316 SS	5,000	2,265
ZCS7094	2.00 - 2.50	51 - 63	22	565	316 SS	8,940	4,056
ZCS7095	2.50 - 3.00	63 - 76	25	623	316 SS	8,940	4,056
ZCS7096	3.00 - 3.50	76 - 89	29	730	316 SS	13,420	6,089
ZCS7097	3.50 - 4.00	89 - 102	29	730	316 SS	13,420	6,089

HEAVY DUTY SUPPORT GRIPS - DOUBLE EYE ROD CLOSING



Slingco Part No.	Range		Lattice Length		Lattice Material	Approx. Break Load	
	in	mm	in	mm		lb	kg
ZCS7098	0.50 - 0.63	13 - 16	11	277	304 SS	1,370	621
ZCS7099	0.63 - 0.75	16 - 19	12	309	304 SS	2,080	944
ZCS7100	0.75 - 1.00	19 - 25	14	351	304 SS	2,080	944
ZCS7101	1.00 - 1.25	25 - 32	15	391	304 SS	2,680	1,215
ZCS7102	1.25 - 1.50	32 - 38	16	417	304 SS	4,490	2,037
ZCS7103	1.50 - 1.75	38 - 44	19	494	304 SS	4,490	2,037
ZCS7104	1.75 - 2.00	44 - 51	21	537	304 SS	5,000	2,265
ZCS7105	2.00 - 2.50	51 - 63	26	654	304 SS	8,940	4,056
ZCS7106	2.50 - 3.00	63 - 76	25	623	304 SS	8,940	4,056
ZCS7107	3.00 - 3.50	76 - 89	27	693	304 SS	13,420	6,089
ZCS7108	3.50 - 4.00	89 - 102	36	914	304 SS	13,420	6,089

NEED ADDITIONAL RODS OR LACE WIRE?

Call or email your Slingco representative now!

01706 855558

sales@slingco.com

CONDUIT RISER CABLE GRIP - STAINLESS STEEL



Conduit Riser Grips are designed to support cables within conduit. Designed to match standard conduit sizes. These grips come in single and double weave as indicated in the chart below. Also available in Split Ring design for supporting cable already installed or when the end of the cable is not available.

Call 01706 855558 for additional sizes and styles.

Slingco comparison reference numbers and Approximate breaking strengths (lb)

Conduit size inches	Cable sizes diameter inches																	
	0.50 - 0.63	0.63 - 0.75	0.75 - 1.00	1.00 - 1.25	1.25 - 1.50	1.50 - 1.75	1.75 - 2.00	2.0 - 2.5	2.0 - 3.0	2.5 - 3.0	2.5 - 3.5	3.0 - 3.5	3.5 - 4.0	3.5 - 4.0	3.5 - 4.5	4.0 - 4.5	4.5 - 5.0	4.5 - 5.5
	Length inches																	
	8	9	11	12	12	14	15	17	20	18	19	20	18	21	20	21	27	27
0.75	ZCS2690 530																	
1	ZCS2691 490	ZCS2694 790																
1.25	ZCS2692 450	ZCS2695 740	ZCS2698 1,030															
1.5		ZCS2696 690	ZCS2699 970	ZCS2701 1,610														
2	ZCS2693 370	ZCS2697 640	ZCS2700 920	ZCS2702 1,520	ZCS2704 1,610													
2.5			ZCS2171 870		ZCS2705 1,510	ZCS2707 1,610	ZCS2708 2,150											
3				ZCS2703 1,340	ZCS2706 1,400	ZCS2709 1,490	ZCS2710 1,990	ZCS2711 3,260										
3.5								ZCS2714 2,970		ZCS2716 3,260								
4							ZCS2712 1,670	ZCS2713 2,680		ZCS2715 2,890	ZCS4282 4,080	ZCS2717 4,080						
							ZCS4500*	ZCS4501*		ZCS4501*	SPLIT ROD							
5								ZCS5645* 2,150	ZCS2719 2,150		ZCS2721 2,860	ZCS5646* 3,130	ZCS2723 3,130	ZCS3200* 10,000	ZCS4283 3,080	SPLIT ROD	ZCS4277 3,130	
6												ZCS2722 2,240	ZCS2724 2,240	ZCS5647 2,240	ZCS4755 2,240	ZCS3259 4,995	ZCS4284 (4,995)	

*indicates Double Weave

HOOKED EYE RISER POLE CABLE SUPPORT GRIP



Heavy Duty Stainless Steel Grip for outdoor riser pole applications.

Slingco Part No	Range		Lattice Weave	Lattice Length		Approx. Break Load	
	in	mm		in	mm	lb	kg
ZCS5430	2.25 - 2.75	57 - 70	Double	21	533	2,000	910
ZCS5268	3.25 - 3.75	82 - 95	Double	21	533	6,500	2,950
ZCS5062	3.50 - 4.25	89 - 108	Double	21	533	6,500	2,950
ZCS4301	4.0 - 4.50	102 - 114	Double	21	533	6,500	2,950

WIND TURBINE SUPPORT GRIP - HEAVY DUTY THIMBLE OFFSET EYE



Slingco has developed a range of cable grips tailored for the renewable energy sector for use in:

- Cable installation – on-shore and off-shore
- Cable support inside wind turbines
- Cable management

For wind turbines, special features have been adapted to allow for minimal contact with the actual cable while still allowing excellent working loads and cable support.

The Slingco Wind Turbine Support Grip is manufactured from 316 Stainless Steel and provides cable support and control inside the wind turbine. It features rounded copper ferrules and offers reduced cable contact for high vibration environments. Custom grips can be adapted to meet any requirement.

Slingco Part No	Range		Lattice Length		Approx. Break Load	
	in	mm	in	mm	lb	kg
ZCS2844	0.31 - 0.40	8 - 10	19	480	1,455	660
ZCS2845	0.40 - 0.60	10 - 15	17	432	2,284	1,036
ZCS2846	0.60 - 0.80	15 - 20	17	432	2,901	1,316
ZCS2847	0.80 - 0.99	20 - 25	18	461	4,586	2,080
ZCS2848	1.0 - 1.19	25 - 30	16	413	5,467	2,480
ZCS2849	1.20 - 1.58	30 - 40	19	470	7,716	3,500
ZCS2850	1.58 - 1.98	40 - 50	32	825	10,781	4,890
ZCS2851	1.98 - 2.37	50 - 60	30	751	10,791	4,895
ZCS2852	2.38 - 2.77	60 - 70	31	788	14,163	6,424
ZCS2853	2.77 - 3.55	70 - 90	45	1,135	14,163	6,424
ZCS2854	3.55 - 4.33	90 - 110	31	799	18,367	8,331

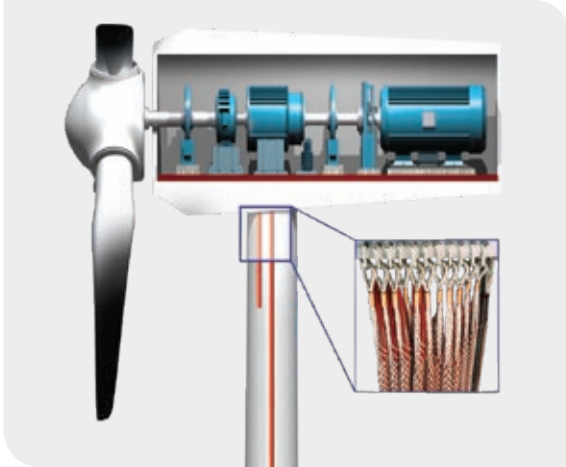

EXTENDED THIMBLE EYE HEAVY DUTY DOUBLE WEAVE STAINLESS STEEL CABLE GRIP



Slingco Part No	Range		Lattice Length		Eye Extension Length		Approx. Break Load	
	in	mm	in	mm	in	mm	lb	kg
ZCS2870	0.39 - 0.60	10 - 15	17	438	17	435	2,295	1,040
ZCS2871	0.60 - 0.80	15 - 20	16	411	17	442	2,903	1,315
ZCS2872	0.80 - 0.99	20 - 25	18	461	18	450	4,590	2,082
ZCS2873	1.0 - 1.19	25 - 30	16	413	18	455	5,468	2,480
ZCS2874	1.20 - 1.58	30 - 40	17	440	18	463	7,898	3,582

TRI & QUAD PULLING SLING

This staggered Pulling Sling is designed to allow the pulling of multiple conductors at the same time while minimizing the overall diameter of your pulling bundle. These pulling slings come in a three leg or four leg versions. One should use a swivel for each leg and at the head of the sling to release torsion and allow the conductors to rotate freely. The suggested swivels are listed with each model.



Slingco Part No.	Leg 1 Length		Leg 2 Length		Leg 3 Length		Leg 4 Length		Head of Sling Swivel Suggestion	Leg Swivel Suggestion
	in	mm	in	mm	in	mm	in	mm		
ZSH2264	20.5	520	34.65	880	52.75	1340	n/a	n/a	ZSW2094	ZSW2092
ZSH2265	20.5	520	34.65	880	52.75	1340	69.3	1760	ZSW2096	ZSW2092



Working Load Limit (3:1) 2,300 lb per leg; 7,100 lb full assembly

LU TYPE - LACE UP CABLE GRIP



Ideal for pulling light to medium loads; the LU Type is fitted to the cable being pulled by stitching it together, like a football. Mainly used where a 'typical' cable grip can't be fitted over a connector at the end of a cable. For use in pulling when the end is not accessible. The LU Type is wrapped around the cable, then closed with the wire lace provided. Both eye loops may be inserted into the same swivel, clevis, shackle or hook to allow pulling.

Slingco Part No	Range		Lattice Weave	Lattice Length		Overall Length		Approx. Break Load	
	in	mm		in	mm	in	mm	lb	kg
LACE UP STANDARD GRIP - GALVANISED									
ZCS1157	0.25 - 0.50	6 - 13	Single	8	230	17	305	1,680	760
ZCS0872	0.50 - 0.75	13 - 19	Single	17	355	22	430	2,240	1,015
ZCS0871	0.75 - 1.00	19 - 25	Single		405	19	510	5,600	2,540
ZCS0328	1.00 - 1.50	25 - 38	Single	15	455	22	610	6,000	3,555
ZCS0329	1.50 - 2.00	38 - 50	Double	27	535	36	735	11,200	5,080
ZCS0330	2.00 - 2.50	50 - 63	Double	26	610	36	865	11,200	5,080
ZCS0331	2.50 - 3.50	63 - 89	Double	22	685	31	990	13,440	6,095
ZCS0853	3.50 - 4.50	89 - 115	Double	27	685	39	990	15,680	7,110
ZCS1109	4.50 - 5.50	115 - 140	Double	27	685	39	990	15,680	7,110
ZCS4463	4.72 - 5.90	120 - 150	Triple	59	1,500	102	2,600	32,928	14,700
ZCS3584	5.31 - 6.30	135 - 160	Double	39	1,000	63	1,600	38,080	17,000
ZCS3585	6.33 - 7.48	161 - 190	Double	59	1,500	83	2,100	38,080	17,000
ZCS3586	7.51 - 8.66	191 - 220	Double	59	1,500	83	2,100	38,080	17,000
ZCS3587	8.70 - 9.84	221 - 250	Double	59	1,500	83	2,100	38,080	17,000
ZCS3588	9.88 - 11.81	251 - 300	Double	79	2,000	106	2,700	38,080	17,000
LACE UP STANDARD GRIP - 316 STAINLESS STEEL									
ZCS1983	0.25 - 0.50	6 - 13	Single	9	230	12	305	1,344	610
ZCS1796	0.50 - 0.75	13 - 19	Single	14	355	17	430	1,792	810
ZCS1789	0.75 - 1.00	19 - 25	Single	16	405	20	510	4,480	2,030
ZCS1797	1.00 - 1.50	25 - 38	Single	18	455	24	610	6,272	2,845
ZCS1984	1.50 - 2.00	38 - 50	Double	21	535	29	735	8,960	4,065
ZCS2466	2.00 - 2.50	50 - 63	Double	24	610	34	865	8,960	4,065
ZCS0816	2.50 - 3.50	63 - 89	Double	27	685	39	990	10,752	4,875
ZCS5094	2.75 - 3.44	69 - 87	Multiple	55	1,390	81	2,063	40,000	17,857
ZCS1356	3.50 - 4.50	89 - 115	Double	27	685	39	990	12,544	5,690
ZCS2832	3.50 - 4.50	89 - 115	Triple	27	685	39	990	14,012	6,300
ZCS1355	4.50 - 5.50	115 - 140	Double	27	685	39	990	12,544	5,690
ZCS2833	4.50 - 5.50	115 - 140	Triple	27	685	39	990	16,128	7,315

SE TYPE - SINGLE EYE CABLE GRIP (MEDIUM-LIGHT DUTY)



Ideal for pulling light to medium loads; typical application - 'standard pull' of single or group of cables. Available in Galvanised and 316 Stainless Steel.

Slingco Part No	Range		Lattice Weave	Lattice Length		Overall Length		Approx. Break Load	
	in	mm		in	mm	in	mm	lb	kg
SINGLE EYE STANDARD GRIP - GALVANISED									
ZCS0320	0.25 - 0.50	10 - 13	Single	9	230	12	305	1,680	760
ZCS0321	0.50 - 0.75	13 - 19	Single	14	355	17	430	2,240	1,015
ZCS0322	0.75 - 1.00	19 - 25	Single	16	405	20	510	5,600	2,540
ZCS0323	1.00 - 1.50	25 - 38	Single	18	455	24	610	7,840	3,555
ZCS0324	1.50 - 2.00	38 - 50	Double	21	535	29	735	8,800	3,992
ZCS0325	2.00 - 2.50	50 - 63	Double	24	610	34	865	11,200	5,080
ZCS0326	2.50 - 3.50	63 - 89	Double	27	685	39	990	13,440	6,095
ZCS0327	3.50 - 4.50	89 - 115	Double	27	685	39	990	15,680	7,110
ZCS0821	4.50 - 5.50	115 - 140	Double	27	685	39	990	15,680	7,110
SINGLE EYE STANDARD GRIP - 316 STAINLESS STEEL									
ZCS1380	0.25 - 0.50	10 - 13	Single	9	230	12	305	1,344	610
ZCS1523	0.50 - 0.75	13 - 19	Single	14	355	17	430	1,792	810
ZCS1373	0.75 - 1.00	19 - 25	Single	16	405	20	510	4,480	2,030
ZCS1952	1.00 - 1.50	25 - 38	Single	18	455	24	610	6,272	2,845
ZCS1381	1.50 - 2.00	38 - 50	Double	21	535	29	735	8,960	4,065
ZCS1977	2.00 - 2.50	50 - 63	Double	24	610	34	865	8,960	4,065
ZCS1979	2.50 - 3.50	63 - 89	Double	27	685	39	990	10,752	4,875
ZCS1980	3.50 - 4.50	89 - 115	Double	27	685	39	990	12,544	5,690
ZCS1981	4.50 - 5.50	115 - 140	Double	27	685	39	990	12,544	5,690

ST TYPE - SINGLE EYE DOUBLE WEAVE CABLE GRIP (MEDIUM DUTY)



Slingco Part No	Range		Lattice Length		Approx. Break Load	
	in	mm	in	mm	lb	kg
SHORT LENGTH - GALVANISED STEEL						
ZCS2511	0.50 - 0.62	13 - 16	21	534	4,500	2,040
ZCS2512	0.62 - 0.75	16 - 19	24	610	5,600	2,540
ZCS2513	0.75 - 1.00	19 - 25	24	610	6,800	3,085
ZCS2514	1.00 - 1.50	25 - 38	24	610	9,600	4,355
ZCS2515	1.50 - 2.00	38 - 50	24	610	16,400	7,441
ZCS2516	2.00 - 2.50	50 - 63	24	610	18,500	8,390
ZCS2517	2.50 - 3.00	63 - 76	24	610	24,500	11,115
ZCS2518	3.00 - 3.50	76 - 89	24	610	24,500	11,115
ZCS2519	3.50 - 4.00	89 - 102	26	660	31,000	14,065
LONGER LENGTH - GALVANISED STEEL						
ZCS2520	0.75 - 1.00	19 - 25	36	914	6,800	3,085
ZCS2521	1.00 - 1.50	25 - 38	36	914	9,600	4,355
ZCS2522	1.50 - 2.00	38 - 50	36	914	16,400	7,440
ZCS2523	2.00 - 2.50	50 - 63	36	914	18,500	8,390
ZCS2524	2.50 - 3.00	63 - 76	36	914	24,500	11,115
ZCS2777	3.00 - 3.50	76 - 89	36	914	24,500	11,115
ZCS2778	3.50 - 4.00	89 - 102	40	1,010	31,000	14,065

The Slingco ST Type Grip features a double weave construction for medium to heavy pulling applications in underground installations.

OS TYPE – OFFSET EYE CABLE GRIP



Slingco Part No	Range		Lattice Weave	Lattice Length		Overall Length		Approx. Break Load	
	in	mm		in	mm	in	mm	lb	kg
OFFSET EYE STANDARD GRIP - GALVANISED									
ZCS1860	0.25 - 0.50	6 - 13	Single	9	230	12	305	1,680	760
ZCS1861	0.50 - 0.75	13 - 19	Single	14	355	17	430	2,240	1,015
ZCS1862	0.75 - 1.00	19 - 25	Single	16	405	20	510	5,600	2,540
ZCS1863	1.00 - 1.50	25 - 38	Single	18	455	24	610	7,840	3,555
ZCS1864	1.50 - 2.00	38 - 50	Double	21	535	29	735	11,200	5,080
ZCS1865	2.00 - 2.50	50 - 63	Double	24	610	34	865	11,200	5,080
ZCS1866	2.50 - 3.50	63 - 89	Double	27	685	39	990	13,440	6,095
ZCS1867	3.50 - 4.50	89 - 115	Double	27	685	39	990	15,680	7,110
ZCS1974	4.50 - 5.50	115 - 140	Double	27	685	39	990	15,680	7,110
OFFSET EYE STANDARD GRIP - 316 STAINLESS STEEL									
ZCS1986	0.25 - 0.50	6 - 13	Single	9	230	12	305	1,344	610
ZCS1987	0.50 - 0.75	13 - 19	Single	14	355	17	430	1,792	810
ZCS1988	0.75 - 1.00	19 - 25	Single	16	405	20	510	4,480	2,030
ZCS1989	1.00 - 1.50	25 - 38	Single	18	455	24	610	6,272	2,845
ZCS1990	1.50 - 2.00	38 - 50	Double	21	535	29	735	8,960	4,065
ZCS1991	2.00 - 2.50	50 - 63	Double	24	610	34	865	8,960	4,065
ZCS1992	2.50 - 3.50	63 - 89	Double	27	685	39	990	10,752	4,875
ZCS1993	3.50 - 4.50	89 - 115	Double	27	685	39	990	12,544	5,690
ZCS1994	4.50 - 5.50	115 - 140	Double	27	685	39	990	12,544	5,690

Similar to the SE Type Single Eye Cable Grip, but for when offset positioning is required. Excellent for pulling slack out of lines that have been pulled. May also be used for removing underground cables when end of cable is available.

JUNIOR TYPE CABLE GRIP (LIGHT DUTY)

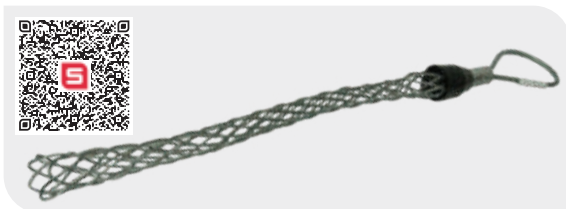

Slingco Part No	Range		Lattice Length (M)		Eye Length (B)		Approx. Break Load	
	in	mm	in	mm	in	mm	lb	kg
ZCS8562	0.25 - 0.36	6.4 - 9.1	7.5	190.5	2.5	63.5	450	204
ZCS8563	0.37 - 0.49	9.4 - 12.4	11.0	279.4	3.0	76.2	900	408
ZCS8564	0.50 - 0.61	12.7 - 15.5	12.5	317.5	3.0	76.2	1,300	589
ZCS8643	0.50 - 0.75	12.7 - 19.0	16.5	419.1	4.5	114.3	2,240	1,016
ZCS8565	0.62 - 0.74	15.7 - 19.0	16.5	419.1	4.5	114.3	1,950	884
ZCS8566	0.75 - 0.99	19.1 - 25.1	17.0	431.8	4.0	101.6	2,800	1,270
ZCS8567	1.00 - 1.25	25.4 - 31.5	17.5	444.5	4.5	114.3	3,900	1,769

Light Duty Pulling Grips. Designed with flexible eye and made of galvanised wire. Use for lighter weight pulling applications like pulling through conduit runs or indoor pulls.

DIRECTIONAL DRILLING SWIVELS

Slingco Directional Drilling Swivels are designed to counter rotational forces caused by boring equipment used in underground pulling and drilling applications. Grease nipple included for removal of dirt and contaminants. Made of carbon steel and zinc passivated for durability. Contains high-strength hex pins. Quality tested and inspected to ensure optimum reliability and performance.



Slingco Part No	Safe Working Load (3:1)		A	Ø B		C	D		Ø E		F			
	lb	kN		in	mm		in	mm	in	mm		in	mm	
ZSW11133	8,500	37.8	7.24	183.8	1.62	41.2	0.63	16.0	1.60	40.6	0.53	13.4	0.55	13.9
ZSW11134	10,000	44.4	8.32	211.3	2.00	50.8	0.75	19.0	1.77	45.0	0.59	14.9	0.75	19.0

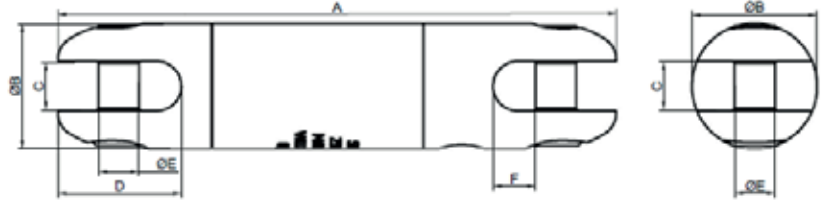

OPEN ENDED CABLE GRIP

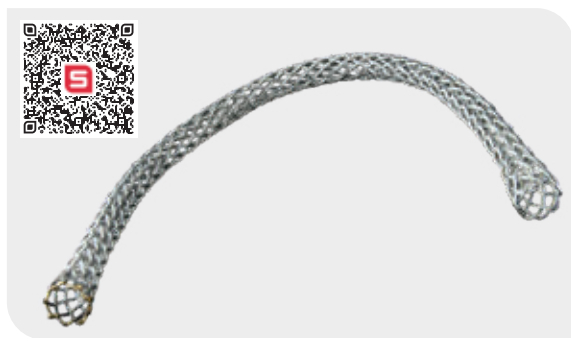

Slingco Part No	Range		Lattice Weave	Lattice Length		Approx. Break Load	
	in	mm		in	mm	lb	kg
OPEN ENDED STANDARD GRIP - GALVANISED							
ZCS0313	0.25 - 0.50	6 - 13	Single	15	380	1,680	760
ZCS6420	0.25 - 0.50	6 - 13	Double	22	559	3,500	1,588
ZCS0314	0.50 - 0.75	13 - 19	Single	24	610	2,240	1,015
ZCS6421	0.50 - 0.75	13 - 19	Double	30	762	4,500	2,040
ZCS6425	0.50 - 0.75	13 - 19	Multi	70	1,779	7,500	3,400
ZCS0315	0.75 - 1.00	19 - 25	Single	28	710	5,600	2,540
ZCS6422	0.75 - 1.00	19 - 25	Triple	30	762	8,000	3,630
ZCS6426	0.75 - 1.00	19 - 25	Multi	80	2,032	11,800	5,352
ZCS0316	1.00 - 1.50	25 - 38	Single	32	815	7,840	3,555
ZCS6423	1.00 - 1.50	25 - 38	Double	36	915	10,000	4,537
ZCS6427	1.00 - 1.50	25 - 38	Multi	90	2,285	20,000	9,070
ZCS0317	1.50 - 2.00	38 - 50	Double	36	915	11,200	5,080
ZCS0318	2.00 - 2.50	50 - 63	Double	42	1,065	11,200	5,080
ZCS1158	2.50 - 3.50	63 - 89	Double	48	1,220	13,440	6,095
ZCS1159	3.50 - 4.50	89 - 115	Double	54	1,370	15,680	7,110
ZCS6424	4.25 - 4.88	108 - 124	Triple	55	1,400	19,500	8,847
ZCS1975	4.50 - 5.50	115 - 140	Double	54	1,370	15,680	7,110
OPEN ENDED STANDARD GRIP - 316 STAINLESS STEEL							
ZCS1995	0.25 - 0.50	6 - 13	Single	15	380	1,344	610
ZCS1996	0.50 - 0.75	13 - 19	Single	24	610	1,792	810
ZCS1997	0.75 - 1.00	19 - 25	Single	28	710	4,480	2,030
ZCS1998	1.00 - 1.50	25 - 38	Single	32	815	6,272	2,845
ZCS1999	1.50 - 2.00	38 - 50	Double	36	915	8,960	4,065
ZCS2000	2.00 - 2.50	50 - 63	Double	42	1,065	8,960	4,065
ZCS2001	2.50 - 3.50	63 - 89	Double	48	1,220	10,752	4,875
ZCS2002	3.50 - 4.50	89 - 115	Double	54	1,370	12,544	5,690
ZCS2003	4.50 - 5.50	115 - 140	Double	54	1,370	12,544	5,690

Ideal for joining two cables to form a continuous loop. Typical application: replacement of lift cables, where the old cable would be attached to the new one, and the cable then fed around with ease. Also used to temporarily splice cable and conductor where torsion forces are NOT an issue. Torsion should be released prior to splicing. Where torsion is present a swivel and two grips should be used.



Slingco Part No.	Range in (mm)	Weave (Coated Galv. Wire)	Lattice Length in (mm)	Eye Opening in (mm)	Approx. Break lb (kg)
SINGLE EYE SINGLE / DOUBLE WEAVE PVC COATED GALVANISED - 0.25 - 0.50" (6 - 13mm)					
ZCS6355	0.25-0.50 (6 - 13)	Single	18 (457)	0.70 (18)	1,500 (680)
ZCS6356	0.25-0.50 (6 - 13)	Single	24 (610)	0.70 (18)	1,500 (680)
ZCS6357	0.25-0.50 (6 - 13)	Double uncoated	18 (457)	0.70 (18)	3,500 (1,588)
ZCS6358	0.25-0.50 (6 - 13)	Double uncoated	24 (610)	0.70 (18)	3,500 (1,588)
ZCS8717	0.25-0.50 (6 - 13)	Triple	24 (610)	Swivel Connector	4,000 (1,814)
SINGLE EYE SINGLE / DOUBLE / TRIPLE WEAVE PVC COATED GALVANISED - 0.50 - 0.75" (13 - 19MM)					
ZCS6359	0.50-0.75 (13 - 19)	Single	18 (457)	0.70 (18)	1,500 (680)
ZCS6360	0.50-0.75 (13 - 19)	Single	24 (610)	0.70 (18)	1,500 (680)
ZCS6361	0.50-0.75 (13 - 19)	Double uncoated	18 (457)	0.70 (18)	4,000 (1,814)
ZCS6362	0.50-0.75 (13 - 19)	Double uncoated	24 (610)	0.70 (18)	4,000 (1,814)
ZCS6363	0.50-0.75 (13 - 19)	Triple	12 (305)	0.87 (22)	5,200 (2,359)
ZCS6364	0.50-0.75 (13 - 19)	Triple	18 (457)	0.87 (22)	5,200 (2,359)
ZCS6365	0.50-0.75 (13 - 19)	Triple	24 (610)	0.87 (22)	5,200 (2,359)
ZCS6366	0.50-0.75 (13 - 19)	Triple	36 (914)	0.87 (22)	5,200 (2,359)
ZCS8718	0.50-0.75 (13 - 19)	Triple	24 (610)	Swivel Connector	8,480 (3,875)
SINGLE EYE SINGLE / DOUBLE / TRIPLE WEAVE PVC COATED GALVANISED - 0.75 - 1.25" (19-32MM)					
ZCS6367	0.75-1.25 (19 - 32)	Single	18 (457)	0.87 (22)	3,000 (1,361)
ZCS6368	0.75-1.25 (19 - 32)	Single	24 (610)	0.87 (22)	3,000 (1,361)
ZCS6369	0.75-1.25 (19 - 32)	Double	18 (457)	0.87 (22)	6,000 (2,722)
ZCS6370	0.75-1.25 (19 - 32)	Double	24 (610)	0.87 (22)	6,000 (2,722)
ZCS6371	0.75-1.25 (19 - 32)	Triple	18 (457)	0.87 (22)	7,500 (3,402)
ZCS6372	0.75-1.25 (19 - 32)	Triple	24 (610)	0.87 (22)	10,000 (4,537)
ZCS8719	0.75-1.25 (19 - 32)	Triple	25.5 (650)	Swivel Connector	6,000 (2,722)
SINGLE EYE TRIPLE WEAVE PVC COATED GALVANISED - 1.25 - 4.88" (32 - 124MM)					
ZCS6373	1.25-2.0 (32 - 51)	Triple	26 (660)	1.42 (36)	7,500 (3,402)
ZCS6374	1.25-2.0 (32 - 51)	Triple	32 (813)	1.42 (36)	10,500 (4,764)
ZCS8720	1.25-2.0 (32 - 51)	Triple	30 (762)	Swivel Connector	10,500 (4,764)
ZCS6375	2.0-2.75 (51 - 70)	Triple	32 (813)	1.91 (48.5)	10,500 (4,764)
ZCS6376	2.0-2.75 (51 - 70)	Triple	38 (965)	1.91 (48.5)	13,500 (6,125)
ZCS8721	2.0-2.75 (51 - 70)	Triple	36 (914)	Swivel Connector	13,500 (6,125)
ZCS6377	2.75-3.5 (70 - 89)	Triple	38 (965)	1.91 (48.5)	13,500 (6,125)
ZCS6378	2.75-3.5 (70 - 89)	Triple	46 (1,168)	1.91 (48.5)	16,500 (7,486)
ZCS8722	2.75-3.5 (70 - 89)	Triple	36 (914)	Swivel Connector	16,500 (7,486)
ZCS6379	3.5-4.25 (89 - 108)	Triple	46 (1,168)	1.91 (48.5)	16,500 (7,486)
ZCS6380	3.5-4.25 (89 - 108)	Triple	52 (1,321)	1.91 (48.5)	19,500 (8,847)
ZCS8723	3.5-4.25 (89 - 108)	Triple	36 (914)	Swivel Connector	19,500 (8,847)
ZCS6381	4.25-4.87 (108 - 124)	Triple	52 (1,321)	1.91 (48.5)	18,000 (8,167)
ZCS6382	4.25-4.87 (108 - 124)	Triple	58 (1,473)	1.91 (48.5)	19,500 (8,847)
ZCS8724	4.25-4.87 (108 - 124)	Triple	40.6 (1,030)	Swivel Connector	21,000 (9,375)

This line of grips are specially designed for underground applications. The eye is enclosed in an aluminium tube which provides added support when running within conduit and trenches. Plus these underground pulling grips are made from coated airline wire for added strength and flexibility.

Now with expanded range capacity use one grip for a wider range of diameters. Plus the expanded range allows for easier installation on conductor or any cylindrical object. As with all pulling applications Slingco strongly recommends banding. See grip installation instructions on page 54.

Models WITH Swivel Connector

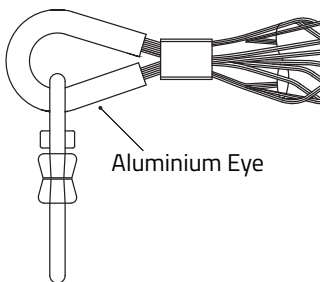

Models WITHOUT Swivel Connector

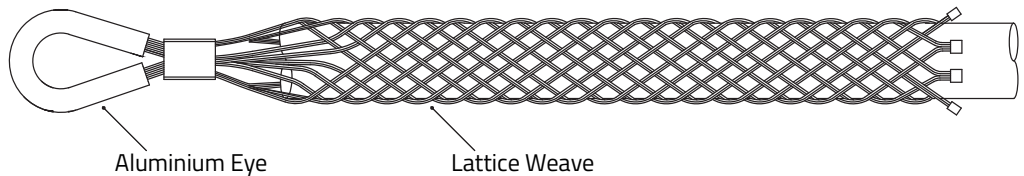

**CATCHBLOCK OVERHEAD LINE
CATENARY ROLLER**
**RECOVER BROKEN CONDUCTORS
WITHOUT ACCESSING PROPERTY
OR INFRASTRUCTURE BELOW**

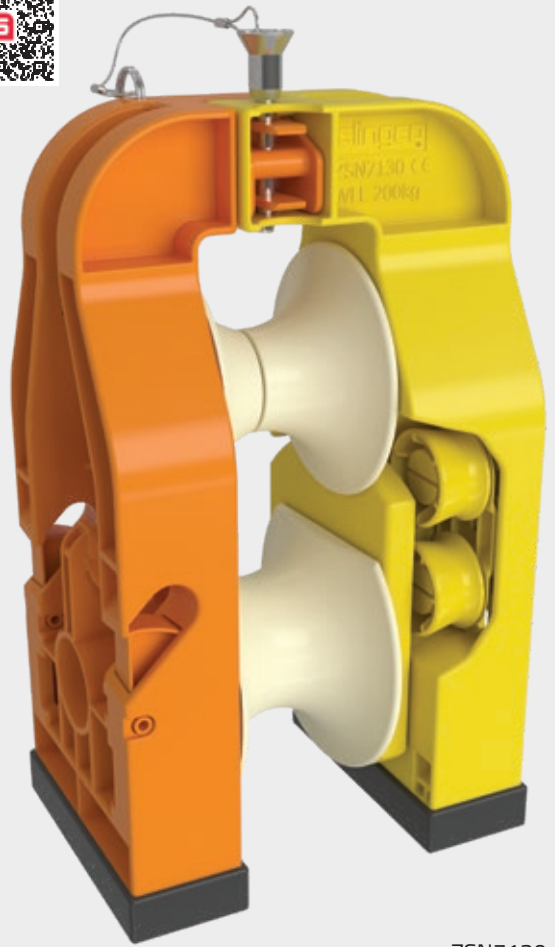

ZSN7130

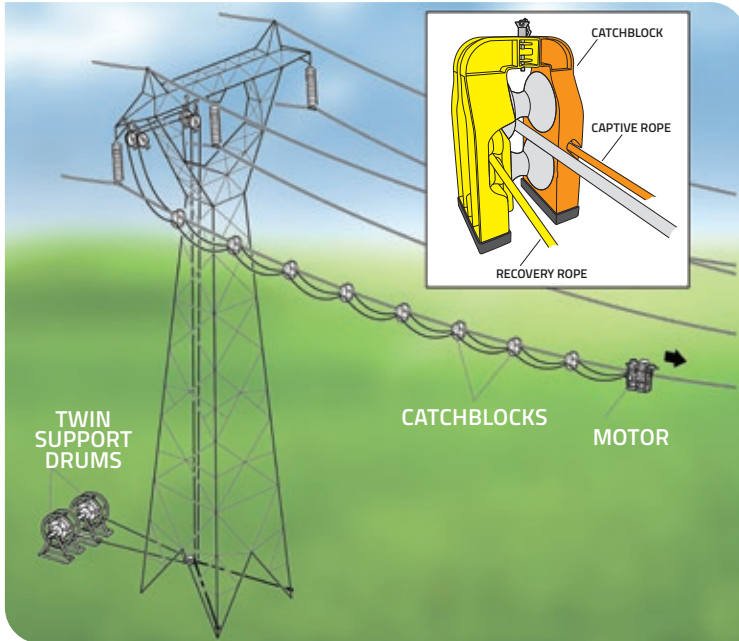

About the CatchBlock system

The challenges faced by the overhead line (OHL) industry due to the growing number of infrastructure projects built beneath existing transmission and distribution networks – alongside increasingly stringent OHL regulations – can make maintenance costly, time-consuming and challenging. Lightweight, robust and easy to deploy, CatchBlock helps overcome these issues, increasing efficiency and reducing costs.

CatchBlock is an innovative OHL catenary roller system. Designed to deploy a two-rope system, it allows the recovery of broken conductors without accessing the property or infrastructure below.

Though most off-the-shelf systems offer efficient single rope deployment, they frequently fail to meet the specifications required by third party clients who own property below overhead conductors. The CatchBlock system not only satisfies the most demanding requirements, but also, because it eliminates the need to shut down essential infrastructure for conductor repairs or in the event of an emergency, estimating maintenance and refurbishment projects costs easier and more accurate.

KEY PRODUCT FEATURES

- Securely holds the deployment ropes without needing bonded ferrules
- Dual rope system tensioned simultaneously to prevent flipping
- CatchBlock prevents excess slack in sub-spans by automatically adjusting position via yellow rope
- Rope colour coordinated to CatchBlock for easy deployment
- No tools required for CatchBlock installation
- System approved and accepted by National Grid, National Highways, and National Rail in the UK

Slingco Part No.	Description	WLL	Weight	Dimensions
ZSN7130	CatchBlock	440 lb (200 kg)	5.0 lb (2.26 kg)	6.9" x 4.7" x 11.4" (17.5 x 12 x 29 cm)

How the CatchBlock system works

Although off-the-shelf, single-rope systems are built to handle broken conductors, if a break happens in a span, over or near an obstacle, two loose ends of the conductor may be left hanging over the obstacle.

The CatchBlock system combines a support rope and a recovery rope so that, in the event of conductor failure (figure 1), both the conductor and CatchBlock system can be

returned to the towers on both sides of the obstacle by pulling back the support rope and leaving the recovery rope in place (figure 2).

The CatchBlock system can then be easily redeployed (figure 3) on the recovery rope and tensioned as normal. The initial recovery rope is then disconnected and joined up to the two conductor ends to pull one end towards the other and re-connect them (figure 4).

Unlike conventional systems, the CatchBlock retains both deployment ropes at all times, avoiding any slack between the rollers. This means that even during the recovery phase the support rope is captured, and distance is maintained between the rollers. Both ropes are always controlled and are not allowed to run freely in any of the roller mechanisms.

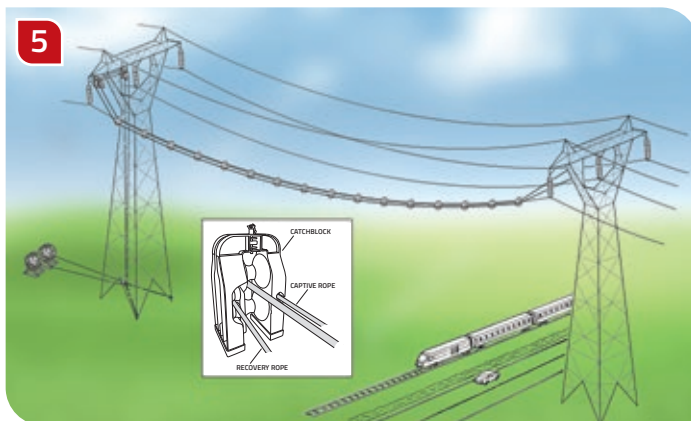
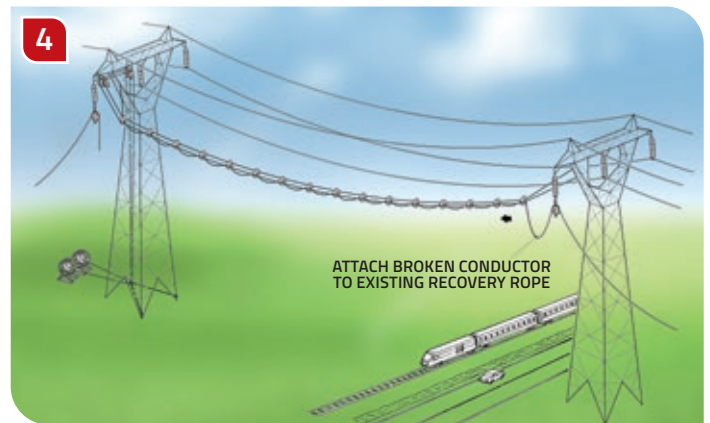
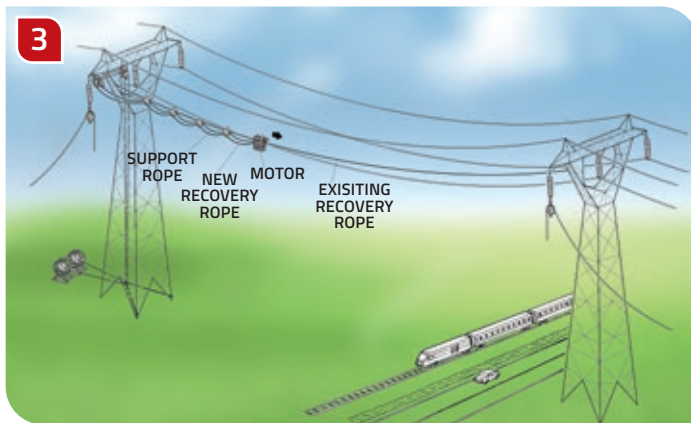
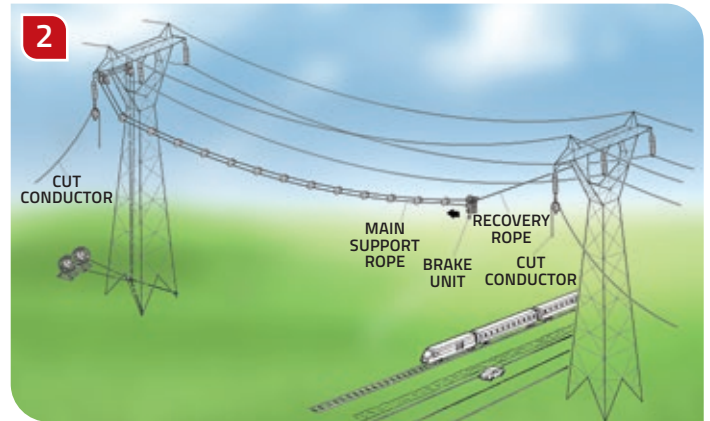
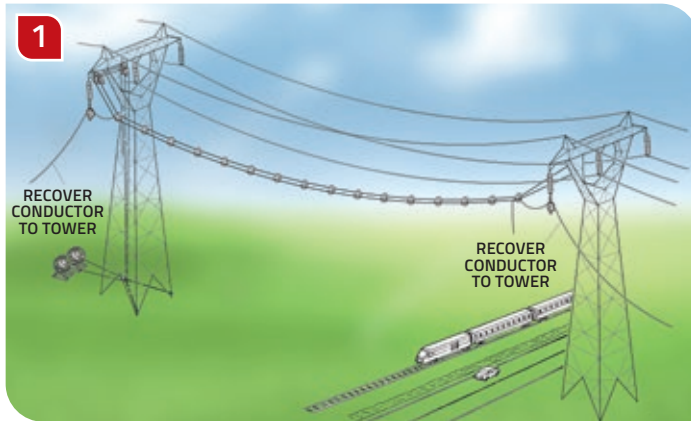

THE CATCHBLOCK SYSTEM
COMBINES A SUPPORT ROPE
AND A RECOVERY ROPE

IN THE EVENT OF CONDUCTOR
FAILURE BOTH CONDUCTOR AND
CATCHBLOCK CAN BE RECOVERED

REMOTELY OPERATED CABLE TUG UNIT



Slingco's Remotely Operated Cable Tug Unit is a remotely operated, motorised aluminium chassis tug unit used for reconductoring over hazards or infrastructure.

The compact unit is powered using a rechargeable Li-Ion battery which makes for quick onsite changeover in remote areas and designed to be used with conductor replacement systems and inspection devices. The unit comes complete with a standard recovery device.

- Max tractive effort of 132 lb (60 kg), up to 88 lb (40 kg) on a 20° incline and 0.787" (20 mm) conductor*
- Automatic soft start - 2.5 mph (4 kph) with approximately 120 minutes of run time using a fully charged 12 AH battery
- Electrically driven using an 18V rechargeable Li-Ion battery
- Remote controlled within 1,600 ft (500 m)
- Operates on conductor/rope diameters from 0.375" to 1.65" (14-42 mm)
- Smooth transition over mid-span joints/connectors up to 2.1" (54 mm)
- Deployable from any direction with forward and reverse modes
- Dedicated lifting point
- Fully recoverable from either end

* Tractive effort will be increased on larger diameter conductors

Slingco Part No.	Description	Dimensions	Weight
ZSN13024	Remotely Operated Cable Tug Unit	31.5" x 19.7" x 11.8" (80 x 50 x 30 cm)	68 lb (31 kg) - including battery
ZSN16197*	18V Rechargeable Li-Ion Battery		3.3 lb (1.5 kg)
ZSN13024	Recovery device	16.5" x 11.8" x 7.9" (42 x 30 x 20 cm)	32 lb (14.5 kg)

* Comes included with the Tug Unit

BOLLARD CLAMP



The Bollard Clamp is an easy to use tensioning device that can be used without risk of damage to the tensioned rope. This is a major advantage over standard types of gripping devices, which could potentially crush or compress the rope or its outer coating.

Installation of the Bollard Clamp is simple, requiring no tools, and the device can be fitted anywhere along the length of the rope using a spring-loaded rope captivation lever. Once installed, the clamp utilises the friction created over a large area of the rope to enable the required tension to the specified WLL.

- Tension without damage to rope, outer coating or underlying layers
- Secures the rope up to 3X WLL and proof loaded to 1.5X WLL
- Lightweight
- Compatible with 0.47" to 0.787" (12-20 mm) diameter ropes

Slingco Part No.	WLL	Material	Weight	Barrel Diameter	Rope Compatibility
ZSN11372	3,800 lb (17 kN)	Aluminium (6082/1050)	6.5 lb (3 kg)	7.87" (200 mm)	0.47" - 0.787" (12-20mm)

Figures given above are indicative only. Nominal figures/actuals are as per datasheet with tolerances of +/-5%. Datasheets available on request.

CAN'T FIND THE SPECIFICATION YOU NEED?

Call or email for full ranges plus custom manufacture options

01706 855558

sales@slingco.com

CONDUCTOR REPLACEMENT ROLLER



The Conductor Replacement Roller (CRR) provides a simple, conductor-deployed protection system using a lightweight aramid rope.

The CRR unit enables the safe exchange of conductors in three easy steps:

1. Laying out the pulling cable, e.g. with Remotely Operated Cable Tug Unit.
2. Tensioning the CRR Block assembly.
3. Feeding a new conductor through the cable pulleys of the CRR Block.

The CRR rollers have spring loaded gripping feature to secure the rope laterally without impeding any rotational movement as the rollers rotate around the axis of the conductor. Considerable effort has been made to reduce the complexity of the design to provide a simple mechanism to hold the rope and then connect around the conductor.

Designed for rapid deployment and secure connection, the external locking mechanism can be inspected from ground level.

- 30% glass filled Nylon 6 from custom mold tooling.
- Unique design incorporates aperture of 65mm to accept smooth passage of joints and connectors.
- Type registered to industry standards
- Non conductive through use of insulating materials

Slingco Part No.	Weight	WLL	FOS (industry standard)
ZSN11371	2.7 lb (1.25 kg)	401 lb (200 kg)	1,764 lb (800 kg)

HIGH VOLTAGE PULLING ROPE



High Voltage Pulling Rope (HVPR) was initially designed for live-line stringing using the cradle-block method, but its excellent dielectric properties enable it to be used as helicopter longlines, guy lines for transmission towers and short-haul lines for work in live electrical environments, and other applications.

HVPR is a dielectric rope used for stringing and service operations, for installing OPGW, and similar operations. The rope is torque balanced and lightweight.

HVPR is manufactured from high performance aramid fibres with a thermoplastic polyurethane (TPU) coating. HVPR is available in four dimensions as standard (if other types are required, please contact us).

Diameter	0.35 in (9 mm)	0.55 in* (13.85 mm)	0.63 in (16 mm)	0.79 in (20 mm)
Breaking strength (minimum)	7,868 lb (>35 kN)	19,108 lb (>85 kN)	29,225 lb (>130 kN)	44,961 lb (>200 kN)
Weight per metre (nom.)	2.4 oz (68 g/m)	5.7 oz (162 g/m)	8.1 oz (230 g/m)	12.1 (343 g/m)
Elongation at break	3.6%			
Thermal expansion factor	-4.5 x 10 ⁻⁶			
Cross section area (outer)	2.5 in ² (63.6 mm ²)	5.9 in ² (150.6 mm ²)	7.9 in ² (201.0 mm ²)	12.4 in ² (314.2 mm ²)
Cross section (fibre core)	1.7 in ² (43.0 mm ²)	4.6 in ² (117.9 mm ²)	5.2 in ² (133.0 mm ²)	10.5 in ² (265.9 mm ²)
Stiffness	269,770 lb (1,200 kN)	876,755 lb (3,900 kN)	1,461,258 lb (6,500 kN)	2,697,708 lb (12,000 kN)
Final modulus of elasticity	18.8 GPa	26.4 GPa	32.7 GPa	38.6 GPa

*Use with CatchBlock System



FIBREGLASS EXTENSION ARM



Slingco Fibreglass Extension Arms are used to move conductor to create working clearance in congested areas, or as a temporary aid in replacing insulators and/or conductor. The Fibreglass Extension Arm complies with ASTM F711, OSHA 1910.269 (j)(l), and OSHA 1926.957 (a)(l).

The arm is rated for 34.5kV with insulators and 15kV without insulators. It includes a double bracket system that will fit over crossarms up to 6" x 6". The wire holders will accommodate cables up to 1.6" in diameter.

Note: Sold two (2) per box

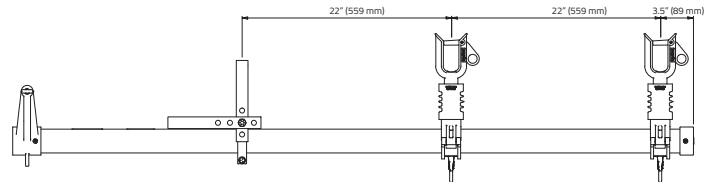

Part No.	Description	Weight (lb)	Weight (kg)	Phase-to-Phase Rating (as supplied)	Max Vertical Load per Wireholder lb (kg)
ITP10989	Crossarm FEA without Insulators	21.2	9.62	15kV	200 (90.72)
ITP10474	Crossarm FEA with Insulators	23.4	10.61	34.5kV	200 (90.72)
ITP10925	Fibreglass Crossarm Retrofit Kit				
ITP14754	Chain Binder Single Conductor	16.5	7.48	34.5kV	200 (90.72)
ITP14726	Chain Binder Double Conductor	21.6	9.79	34.5kV	200 (90.72)
ITP14767	Ratchet Strap Single Conductor	14.8	6.70	34.5kV	200 (90.72)
ITP14771	Ratchet Strap Double Conductor	20.0	9.08	34.5kV	200 (90.72)

JIB HEAD ADAPTER



- For mounting Jib Head attachments and assemblies
- Manufactured from zinc plated steel
- Supplied with machined pin and lanyard

Slingco Part No.	Dimensions (Square ID)		Type
	in	mm	
ZWH10911	4.1 x 4.1	104.1 x 104.1	Square to Round Adapter

CAN'T FIND THE SPECIFICATION YOU NEED?
 Call or email for full ranges plus custom manufacture options

01706 855558
 sales@slingco.com

35KV JUMPER CLAMP



Slingco's Jumper Clamps are used as a part of jumper cable assemblies to bypass work areas when equipment is under repair or being upgraded. Jumper clamps are lightweight and impact resistant making them incredibly durable. We make inspection of the cable, ferrule, and clamp simple and easy via the transparent clamp body. The jaw of the Slingco Jumper Clamp and floating ring contact is made from a copper-based alloy.

Slingco Part No.	Main Line Range	Max. Continuous Amps	Threading	Length	Weight
ZSC09344	954 MCM (0.162 - 1.25)	400	5/8" - 11 threads per inch	11.5" (292mm)	2.5 lb (1.15 kg)
ZSC12110	477 MCM (0.162 - 0.9)	400	5/8" - 11 threads/inch	11.5" (292mm)	2.4 lb (1.09 kg)

NOTE: Slingco Jumper Clamps are sold individually. Slingco Jumper Clamps meet ASTM F2321 standard.

GROUNDING CLAMPS

Slingco's Grounding Clamps meet ASTM F855 and have a maximum line range of up to 2" (50.8mm) which allows them to be used in a wide variety of grounding applications.

Aluminium Grounding Clamps

Slingco's Aluminium Grounding Clamps have a location for a grounding stud which allows for a wide variety of grounding applications. The Slingco Aluminium Clamps come with serrated and a smooth jaw offering.

Bronze Grounding Clamps

Slingco's Bronze Grounding Clamps have set screws in the moveable jaw which allows the user to adjust and make sure there is a secure connection between the clamp and cable. The flat face clamps come with a serrated jaw and are available with a T-handle or Eye Bolt.

- Meets ASTM F855 specification
- Line range up to 2" (50.8 mm)

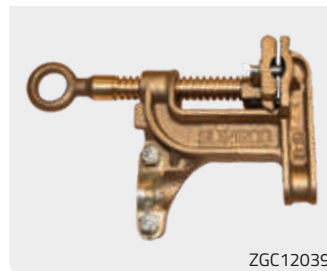
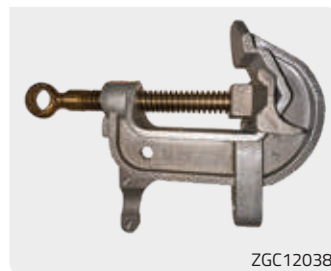
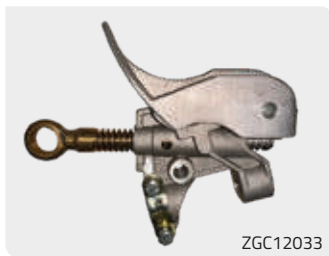

Slingco Part no.	Description	Clamp Material	Eye Type	Class/ASTM Grade	Line Range		Weight	
					in	mm	lb	kg
ZGC12033	Duckbill Clamp w/o Strain Relief	Aluminium	Eye Bolt	Class B/Grade 5H	0.16 - 1.66	4.06 - 42.16	1.85	0.84
ZGC12034	Duckbill Clamp w/ Strain Relief	Aluminium	Eye Bolt	Class B/Grade 5H	0.16 - 1.66	4.06 - 42.16	1.98	0.90
ZGC12035	1.5" (38 mm) C-Clamp w/o Strain Relief	Aluminium	Eye Bolt	Class B/Grade 5	0.16 - 1.50	4.06 - 38.10	1.85	0.84
ZGC12036	1.5" (38 mm) C-Clamp w/ Strain Relief	Aluminium	Eye Bolt	Class B/Grade 5	0.16 - 1.50	4.06 - 38.10	1.98	0.90
ZGC12037	2" (51 mm) C-Clamp w/ Serrated Jaw	Aluminium	Eye Bolt	Class B/Grade 5H	0.16 - 2.00	4.06 - 50.80	2.25	1.02
ZGC12038	2" (51 mm) C-Clamp w/ Smooth Jaw	Aluminium	Eye Bolt	Class A/Grade 5H	0.16 - 2.00	4.06 - 50.80	2.20	1.00
ZGC12039	1.5" (38 mm) Flat Face Grounding	Bronze	Eye Bolt	Class B/Grade 5	0.125 - 1.50	3.18 - 38.10	1.98	0.90
ZGC12040	1.5" (38 mm) Flat Face Grounding	Bronze	T Handle	Class B/Grade 5	0.125 - 1.50	3.18 - 38.10	2.16	0.98

RATCHET CUTTERS



The Slingco ACSR, CUAL, and Guy wire Ratchet Cutters are designed to cut hard cables cleanly and smoothly. The ratchet design provides leverage, increasing cutting force with each open and close of the handles. Makes cutting cable easier compared to manual cutters.

The handles' surfaces are designed to allow a firm, secure grip. The ratcheting action makes these cutters easy to operate even in limited spaces with just moderate pressure.

WARNING: DO NOT use on energised lines.

- Versions for cutting ACSR, Copper/Aluminium cable, and Small Guy Wire
- Smooth ratchet operation even in small spaces
- Strong blades for added durability

Slingco Part No.	Type	Capacity	Length	Weight
TCU09280	ACSR Ratchet Cutter	1/2" Soft Steel, 954 KCMIL ACSR	30" (762 mm)	12 lb (5.44 kg)
TCU09281	CUAL Ratchet Cutter	1,500 KCMIL Copper/Aluminium	30" (762 mm)	12 lb (5.44 kg)
TCU11807	Small Guy Wire Ratchet Cutter	1/2" EHS Guy Wire	29.5" (750 mm)	10.4 lb (4.7 kg)

BOLT CUTTERS



- Superior cutting performance
- Ergonomic comfort
- Fibreglass and steel handles
- Available in 18", 24", 30" and 36" lengths
- Versatile application for hard and soft materials

When your work calls for a reliable, powerful cutting tool, turn to Slingco Bolt Cutters. Designed and built for the demanding, daily use of utility professionals and contractors, these cutters deliver consistent performance.

Our hardened steel blades provide clean, powerful cuts across a wide variety of materials, including soft metals, chain, and rebar. The ergonomic handles are engineered for optimal grip and leverage, which helps reduce operator fatigue and improves control during tough applications.

With a variety of sizes available, Slingco has the right tool for the job, helping you work efficiently and safely.

WARNING: DO NOT use on energised lines.

Material	Slingco Part No.	Part No. Suffix/Length (in)	Hard Cut Capacity (HRC 48)	Soft/Medium Cut Capacity (HRC 19)	Weight
Steel	TCU15812	-18	9/32" (7 mm)	3/8" (10 mm)	3.4 lb (1.5 kg)
		-24	5/16" (8 mm)	7/16" (11 mm)	5.3 lb (2.4 kg)
		-30	3/8" (10 mm)	1/2" (13 mm)	8.4 lb (3.8 kg)
		-36	7/16" (11 mm)	9/16" (14 mm)	11.3 lb (5.1 kg)
Fibreglass	TCU15813	-18	9/32" (7 mm)	3/8" (10 mm)	3.4 lb (1.5 kg)
		-24	5/16" (8 mm)	7/16" (11 mm)	5.2 lb (2.35 kg)
		-30	3/8" (10 mm)	1/2" (13 mm)	8.5 lb (3.85 kg)
		-36	7/16" (11 mm)	9/16" (14 mm)	11.6 lb (5.26 kg)

MECHANICAL CRIMPING TOOL



Slingco's Mechanical Crimping Tools have been created to complete the variety of utility distribution service connections that need to be made on the line, pole, and home. Our crimping tools have been designed to provide reliable crimps installing full-tension or non-tension connectors.

Slingco's Mechanical Crimping Tool's 'D3' groove allows 'W' style die inserts for installing taps, splices, and terminal connectors. The 'W' die inserts lock securely and easily into place with the positive lock, spring-loaded die buttons. Slingco also offers a Mechanical Crimping Tool that accepts Kearney type dies.

Our Mechanical Crimping Tools also have ergonomic handles for comfortable use and maximum leverage when making critical connections.

- 'D3' groove allows 'W' style die inserts for installing taps, splices, and terminal connectors
- The Kearney seat tool accepts Kearney type dies also available from Slingco
- Ergonomic handles for comfortable use and maximum leverage
- Slingco Insert Dies available

Slingco Part No.	Tool Type	Crimping Force		Length		Weight		Die Style
		lb	kg	in	mm	lb	kg	
TCR7002	O Nose Die & D3 Seat	9,000	4,082	25.75	654	7	3.18	Accepts 'W' Style Dies
TCR7004	BG Nose Die & D3 Seat	9,000	4,082	25.75	654	7	3.18	Accepts 'W' Style Dies
TCR08735	16 mm / 5/8 in Nose Die & Kearney Seat	9,000	4,082	25.75	654	7	3.18	Accepts 'Kearney' Type Dies

REPLACEMENT 12 TON WH2/WH3 KEARNEY TYPE



REPLACEMENT W-DIE SETS (D3 INSERT)



Slingco Part No.	Slingco Ref.	Burndy Equiv.
TCR7020	S6-K840	WK840
TCR7021	S6-BG	WBG
TCR7022	S6-O	WO
TCR7023	S6-247	W247
TCR7024	S6-249	W249
TCR7025	S6-121	W121
TCR7027	S6-163	W163
TCR7028	S6-164	W164
TCR7029	S6-165	W165
TCR7030	S6-166	W166
TCR7031	S6-167	W167
TCR7034	S6-237	W237
TCR7036	S6-239	W239
TCR7037	S6-241	W241
TCR7038	S6-243	W243
TCR7039	S6-245	W245
TCR7047	S6-C	WC
TCR7058	S6-25RT	W25RT
TCR7059	S6-26RT	W26RT

REPLACEMENT O-DIE SETS (KEARNEY SEAT)



Slingco Part No.	Slingco Ref.	Kearney Die Size
TCR10117	O Die - 1/2	1/2
TCR10118	O Die - 1/4	1/4
TCR10119	O Die - 3/8	3/8
TCR10120	O Die - 5/8-1	5/8-1
TCR10121	O Die - 5/16	5/16
TCR10122	O Die - 9/16	9/16
TCR10123	O Die - 11/16	11/16
TCR10124	O Die - 19/32	19/32
TCR10125	O Die - 620	620
TCR10126	O Die - 635	635
TCR10127	O Die - 747	747
TCR10128	O Die - 781	781
TCR10129	O Die - 840	840
TCR10130	O Die - 845	845
TCR10131	O Die - B	B
TCR10132	O Die - 3/16	3/16
TCR10133	O Die - T	T
TCR10134	O Die - D	D
TCR10135	O Die - J	J
TCR10136	O Die - K	K
TCR10137	O Die - O	O
TCR10138	O Die - P	P
TCR10139	O Die - 737	737

Slingco Part No.	Slingco Ref.	Kearney Die Size
TCR09864	WH2/WH3 Die - BKT	BKT
TCR09865	WH2/WH3 Die - C	C
TCR09866	WH2/WH3 Die - D	D
TCR09867	WH2/WH3 Die - N	N
TCR09868	WH2/WH3 Die - O	O
TCR09869	WH2/WH3 Die - P	P
TCR09870	WH2/WH3 Die - U	U
TCR09871	WH2/WH3 Die - 510	510
TCR09872	WH2/WH3 Die - 572	572
TCR09873	WH2/WH3 Die - 635	635
TCR09874	WH2/WH3 Die - 727	727
TCR09875	WH2/WH3 Die - 737	737
TCR09876	WH2/WH3 Die - 747	747
TCR09877	WH2/WH3 Die - 781	781
TCR09878	WH2/WH3 Die - 840	840
TCR09879	WH2/WH3 Die - 1/4	1/4
TCR09880	WH2/WH3 Die - 5/16	5/16
TCR09881	WH2/WH3 Die - 3/8	3/8
TCR09882	WH2/WH3 Die - 1/2	1/2
TCR09883	WH2/WH3 Die - 9/16	9/16
TCR09884	WH2/WH3 Die - 19/32	19/32
TCR09885	WH2/WH3 Die - 5/8	5/8
TCR09886	WH2/WH3 Die - 11/16	11/16
TCR09887	WH2/WH3 Die - 15/16	15/16
TCR09888	WH2/WH3 Die - 3/4H	3/4H
TCR09889	WH2/WH3 Die - 29/32	29/32
TCR09890	WH2/WH3 Die - 15/16H	15/16H
TCR09891	WH2/WH3 Die - 1/2/H	1/2/H
TCR09892	WH2/WH3 Die - 1-1/8-1	1-1/8-1
TCR09893	WH2/WH3 Die - 1-1/8-2	1-1/8-2
TCR09894	WH2/WH3 Die - 1-5/16	1-5/16
TCR09895	WH2/WH3 Die - 1-1/2H	1-1/2H
TCR09896	WH2/WH3 Die - 840H Wide	840H Wide

60 TON HYDRAULIC CRIMPING TOOL AND DIES



Slingco's Hydraulic Crimping Tools are designed to crimp sleeves and lugs on ACSR and ACAR transmission & distribution cables using dies that meet the standards of the utility industry. Our crimping tools are ideal for use in constructing substations and transmission lines.

The Single-Acting Crimping Tool uses hydraulic pressure to advance the ram into position, and an internal spring to return the ram to the original position. The Double-Acting Crimping Tool advances and returns the ram using hydraulic pressure alone, eliminating the possibility of the ram sticking or becoming jammed.

Our Hydraulic Crimping Tools come in a steel carrying case, and are lightweight and portable. Our crimping tools accept Slingco S60 Dies, or any shell-type dies used with Alcoa or Burndy 60-ton crimping tools.

- Accepts Slingco, Burndy L and Alcoa 6000 Series dies
- Steel Carrying Case Includes Ground Stand
- Lifting eye for hoist work
- For Crimping ACSR and ACAR transmission and distribution cables

Slingco Part No	Crimping Force	Operating Pressure	Action	Tool Weight	Oil Required
TCR7003	60 Tons	10,000 psi (700 bar)	Single-Action	47 lb	308 cc
TCR7018	60 Tons	10,000 psi (700 bar)	Double-Action	51 lb	314 cc

Replacement Dies for 60-Ton Hydraulic Crimping Tools

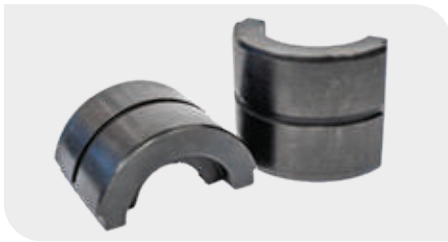

Repair kits

Slingco Part No.	Description	For Crimper No.
TCR09048	Seal Kit	TCR7003 60 Ton Single Action
TCR09937	Detent Kit	TCR7003 60 Ton Single and Double Action
TCR10356	Seal Kit	TCR7018 60 Ton Double Action

Slingco Part No.	Slingco Ref.	Alcoa Equivalent
TCR7067	S60-10SH	6010SH
TCR7068	S60-12SH	6012SH
TCR7069	S60-14SH	6014SH
TCR7070	S60-16SH	6016SH
TCR7071	S60-18SH	6018SH
TCR7072	S60-20SH	6020SH
TCR7073	S60-24SH	6024SH
TCR7074	S60-27SH	6027SH
TCR7075	S60-30SH	6030SH
TCR7076	S60-34SH	6034SH
TCR7077	S60-36SH	6036SH
TCR7078	S60-38AH	6038AH

Slingco Part No.	Slingco Ref.	Alcoa Equivalent
TCR7083	S60-40AH	6040AH
TCR7084	S60-44AH	6044AH
TCR7085	S60-48AH	6048AH
TCR7086	S60-52AH	6052AH
TCR7087	S60-56CD	6056CD
TCR7088	S60-60CD	6060CD
TCR7089	S60-64CD	6064CD
TCR7090	S60-68CD	6068CD
TCR7091	S60-72CD	6072CD
TCR7092	S60-76CD	6076CD
TCR7093	S60-80CD	6080CD
TCR7094	S60-84CD	6084CD
TCR7095	S60-88CD	6088CD
TCR7096	S60-92CD	6092CD
TCR7097	S60-96CD	6096CD
TCR09084	Blank die	-

Performance. Under the toughest conditions.

We test to destruction here, to make sure it doesn't happen out there



100 TON HYDRAULIC CRIMPING TOOL AND DIES



Slingco's 100 Ton Hydraulic Crimping Tool is ideal for use in constructing substations and transmission lines. This tool is designed to crimp sleeves and lugs on ACSR and ACAR transmission cables using dies that meet the standards of the utility industry.

The TCR0849 comes in a single-action configuration but can be converted to double-action functionality.

Crimping Range

- Copper: Up to 2.5" OD Sleeve
- Aluminium: Up to 3" OD Sleeve
- Steel: Up to 1.25" OD Sleeve

Comes with steel carrying case.

- Accepts U or shell type dies
- Steel Carrying Case
- Large handles for easy carrying
- Easy die installation

Slingco Part No	Crimping Force	Operating Pressure	Action	Tool Weight	Oil Required
TCR08490	100 Tons	10,000 psi (700 bar)	Single-Action	78 lb	422 cc

Replacement Dies for 100-Ton Hydraulic Crimping Tools



Slingco Part No.	Slingco Ref.	Alcoa Equivalent
TCR08544	S100-10SH	10010SH
TCR08545	S100-12SH	10012SH
TCR08546	S100-14SH	10014SH
TCR08547	S100-16SH	10016SH
TCR08548	S100-18SH	10018SH
TCR08549	S100-20SH	10020SH
TCR08550	S100-74SH	10074SH
TCR08551	S100-75SH	10075SH
TCR08552	S100-20AH	10020AH
TCR08553	S100-24AH	10024AH
TCR08554	S100-27AH	10027AH
TCR08555	S100-30AH	10030AH
TCR08556	S100-34AH	10034AH
TCR08557	S100-36AH	10036AH
TCR08558	S100-38AH	10038AH
TCR08559	S100-40AH	10040AH
TCR08560	S100-74AH	10074AH
TCR08561	S100-75AH	10075AH
TCR08562	S100-76AH	10076AH

Slingco Part No.	Slingco Ref.	Alcoa Equivalent
TCR08563	S100-42AH	10042AH
TCR08564	S100-44AH	10044AH
TCR08565	S100-46AH	10046AH
TCR08566	S100-48AH	10048AH
TCR08567	S100-07CD	10007CD
TCR08568	S100-08CD	10008CD
TCR08569	S100-09CD	10009CD
TCR08570	S100-10CD	10010CD
TCR08571	S100-11CD	10011CD
TCR08572	S100-12CD	10012CD
TCR08573	S100-13CD	10013CD
TCR08574	S100-14CD	10014CD
TCR08575	S100-15CD	10015CD
TCR08576	S100-16CD	10016CD
TCR08577	S100-17CD	10017CD
TCR08578	S100-18CD	10018CD
TCR08579	S100-19CD	10019CD
TCR08580	S100-20CD	10020CD

Repair kits

Slingco Part No.	Description	For Crimper No.
TCR09048	Seal Kit	TCR7003 60 Ton Single Action
TCR09937	Detent Kit	TCR7003 60 Ton Single and Double Action
TCR10356	Seal Kit	TCR7018 60 Ton Double Action



CAN'T FIND THE SPECIFICATION YOU NEED?

Call or email for full ranges plus custom manufacture options

01706 855558

sales@slingco.com

SHOTGUN STICKS



Slingco Shotgun Sticks are essential tools for live-line work, used by utility crews to safely apply and remove hot line clamps, operate cutouts and switches, apply temporary grounds, and handle energised jumpers and connectors.

- Universal end fitting on all models
- Available in 4', 6', 8', 10', and 12' lengths
- ASTM F711 and F1825 compliant
- Hook opens 90 degrees from handle
- Internal or external rod options

Slingco Part No.		Length		Weight	
		ft-in	m	lb	kg
Shotgun Stick with Internal Operating Rod w/ Universal End					
HLT12963-4	4ft Internal Rod Shotgun Stick	4'10"	1.47	4.3	1.95
HLT12963-6	6ft Internal Rod Shotgun Stick	6'10"	1.78	4.92	2.23
HLT12963-8	8ft Internal Rod Shotgun Stick	8'10"	2.08	5.53	2.51
HLT12963-10	10ft Internal Rod Shotgun Stick	10'10"	2.39	6.15	2.79
HLT12963-12	12ft Internal Rod Shotgun Stick	12'10"	2.69	6.75	3.06
Shotgun Stick with External Operating Rod w/ Universal End					
HLT12964-4	4ft External Rod Shotgun Stick	4'10"	1.47	4.5	2.04
HLT12964-6	6ft External Rod Shotgun Stick	6'10"	1.78	5.22	2.37
HLT12964-8	8ft External Rod Shotgun Stick	8'10"	2.08	6.15	2.79
HLT12964-10	10ft External Rod Shotgun Stick	10'10"	2.39	7.03	3.19
HLT12964-12	12ft External Rod Shotgun Stick	12'10"	2.69	7.78	3.53

UNIVERSAL AND SWITCH HEAD STICKS



- Universal end fitting on all models
- Fits a wide range of lineman tools with a universal attachment
- ASTM F711 compliant
- Includes hanger for quick placement
- Available in 4', 6', 8', 10', and 12' lengths

Slingco's Universal and Switch Head Sticks are designed for safety and ease of operation in high-voltage environments. These hot sticks are trusted by linemen for performing switching, testing, grounding, and disconnect operations on live lines. Made from high-dielectric strength fibreglass, each stick delivers dependable insulation while remaining lightweight and maneuverable.

Note: The Universal Sticks and Switch Head Sticks are supplied without fittings.

Slingco Part No.		Length		Weight	
		ft	m	lb	kg
Universal Stick w/Universal Base					
HLT12961-4	4ft Universal Stick with Universal Base	4	1.22	2.26	1.03
HLT12961-6	6ft Universal Stick with Universal Base	6	1.83	3.00	1.36
HLT12961-8	8ft Universal Stick with Universal Base	8	2.44	3.77	1.71
HLT12961-10	10ft Universal Stick with Universal Base	10	3.05	4.52	2.05
HLT12961-12	12ft Universal Stick with Universal Base	12	3.66	5.27	2.39
Switch Head Stick w/Universal Base					
HLT12962-4	4ft Switch Head Stick with Universal Base	4	1.22	2.51	1.14
HLT12962-6	6ft Switch Head Stick with Universal Base	6	1.83	3.24	1.47
HLT12962-8	8ft Switch Head Stick with Universal Base	8	2.44	4.02	1.82
HLT12962-10	10ft Switch Head Stick with Universal Base	10	3.05	4.77	2.16
HLT12962-12	12ft Switch Head Stick with Universal Base	12	3.66	5.53	2.51
Fittings					
ITP14370	Universal Disconnect Hook			0.4	0.17
ITP14370-P	Fluorescent Universal Disconnect Hook			0.4	0.17

ISOLATING LINK AND SPIRAL LINK STICKS

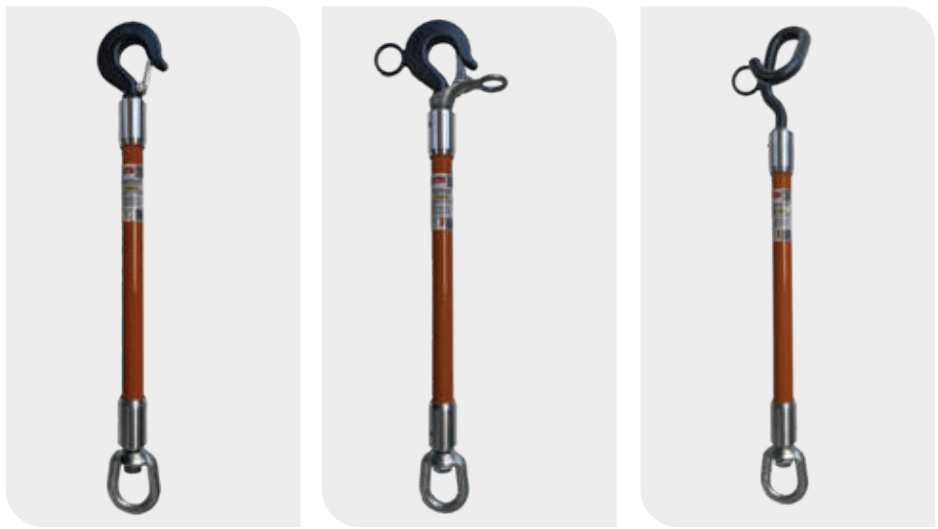

- Added protection when used properly with strap hoists on energised lines
- Compatible with most hoists
- Tested to ASTM F711 standards
- Isolating link sticks come as standard with swivel eye and choice of standard or hot stick operated hook
- Designed for quick connection and easy handling
- Rugged, utility-grade construction

Slingco's Isolating Link and Spiral Link Sticks provide enhanced electrical isolation when used with strap hoists on primary voltage lines. Built tough for utility crews, they're a reliable safeguard for energised work zones.

Slingco's **Isolating Link Sticks** are available in 6 inch (152.5 mm) and 12 inch (305 mm) lengths, each isolating link comes equipped with a swivel eye on one end and your choice of a standard hook or a hot stick operated hook, ensuring compatibility with various jobsite requirements.

Slingco's **Spiral Link Stick** has 12" (305 mm) of fiberglass and is 24" (610 mm) overall. It comes equipped with a swivel eye on one end and a spiral hook on the other.

Slingco Part No.	Description	Fibreglass length in (mm)	Working load limit lb (kg)
HLT13431-6	Isolating Link w/ Standard Hook & Swivel End (6")	6" (152.5)	4,000 (1,814)
HLT13431-12	Isolating Link w/ Standard Hook & Swivel End (12")	12" (305)	4,000 (1,814)
HLT13432-6	Isolating Link w/ Hot Stick Operated Hook & Swivel End (6")	6" (152.5)	4,000 (1,814)
HLT13432-12	Isolating Link w/ Hot Stick Operated Hook & Swivel End (12")	12" (305)	4,000 (1,814)
HLT13433	Spiral Link Stick (24")	12" (305)	2,000 (907)

RUBBER INSULATING BLANKETS



Slingco Insulating Rubber Blankets provide essential electrical insulation for professionals working with high-voltage equipment. Designed for safety and durability, these blankets meet ASTM D1048 standards offering protection up to 36,000V AC.

Made from high-strength, ozone-resistant rubber, Slingco's Type II Blankets provide flexibility in extreme temperatures. These blankets enhance workplace safety by protecting against electrical arcs, shocks, and flashes, making them ideal for utility workers.

- Protection up to 36KV
- Durable ozone resistant material
- Integrated eyelets for use with Slingco blanket magnets
- Compatible for use with Slingco blanket accessories

Slingco Part No.	Description	Solid/ Split	Type*	Class*	Style*	Blanket dimensions					Box dimensions					Blanket Weight		Box Weight	
						A	B	C	D	E	D	E	lb	kg	lb	kg			
PPE08434	Box of 6 36" x 36"	Solid	Type II	4	A	36	910	36	910	37.9	962	10	254	10	254	8.7	3.9	60	27
PPE08432	Box of 6 22" x 22"	Solid	Type II	4	A	22	560	22	560	24.6	625.5	23	584.2	3.4	85.7	3.3	1.5	40	18
PPE09715	Box of 6 22" x 22"	Split	Type II	4	A	22	560	22	560	24.6	625.5	23	584.2	3.4	85.7	3.3	1.5	41	19

*Type, Class, and Style are defined by ASTM D1048.

RUBBER BLANKET ACCESSORIES



Used to hold insulating blankets and other types of rubber coverups in place, Slingco Blanket Clamp Pins, Pole Clamps and Blanket Magnets are constructed of ultraviolet stabilised fibreglass reinforced polymer.

The **Slingco Blanket Clamp Pin** has extra holes in the center of the body and is used to grip conductors and prevent linehose from sliding. Holes have also been placed in the handles to enable attachment of warnings, tags, and/or flags. The handles of the ZPE12136 pin are shaped to engage with the end ferrule of a clampstick (shotgun stick).

The **Slingco Pole Clamp** is meant to eliminate the use of tie wraps, bungee cords, tapes or any other items that can cause damage to insulated rubber products. With Slingco's unique tool handle lock system, the Pole Clamp can be set in an open position by engaging the handle lock. Once the product is in its intended location the lock can be released making installation easier.

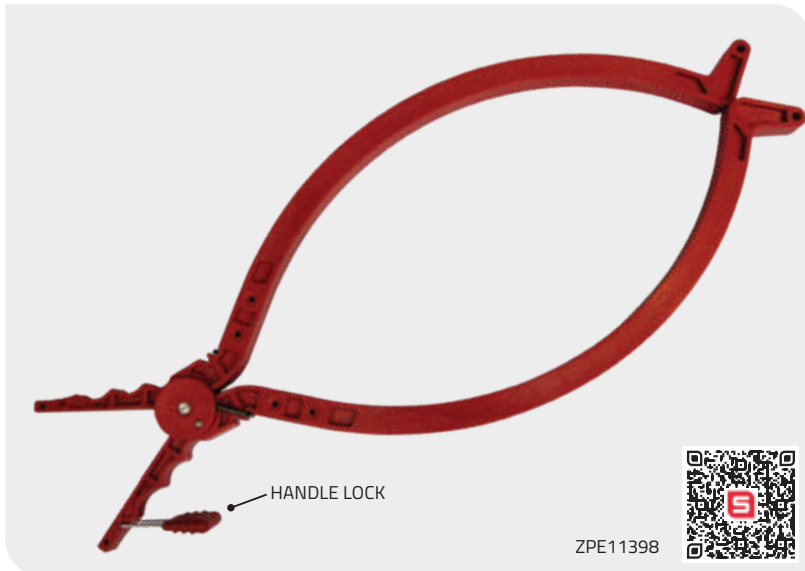

The **Slingco Blanket Magnet** is designed to fit through the eyelets of an insulated blanket. Afterwards, the magnet along with the blanket can be placed over energised areas of transformers, switchboards and substations. Can be used with hot line tools.

Blanket Clamp Pin

Slingco Part No.	Length		Jaw Opening		Weight		Note
	in	mm	in	mm	oz	g	
ZPE10962	9.5	241	5	127	5	141.5	
ZPE12136	9.5	241	5	127	5.4	153	with Hot Stick Clip

Pole Clamp

Slingco Part No.	Length		Width		Jaw Opening		Weight	
	in	mm	in	mm	in	mm	lb	kg
ZPE11399	20.25	514.4	8.25	203.2	13.5	342.9	1.7	0.77
ZPE11398	28	711.2	11.5	291.2	19.75	501.7	2.2	1.0

Blanket Magnet

Slingco Part No.	Height		Diameter		Weight		Magnet rating	
	in	mm	in	mm	lb	g	lb	kg
PPE10785	2.4	60.6	1.75	44.4	0.2	90.7	120	54.4





Features:

- Durable Canvas construction
- Convenient flap closure
- Four Glove Bag options
- Combination Glove & Sleeve bags
- Sleeve only bag available

Protecting your gloves and sleeves is convenient with Slingco canvas bags. Bags feature a hook with latch for attaching to belt plus flap closure. Glove bags come in four sizes 12", 14", 16" and 18".

Compact and full-size Combination Glove & Sleeve bags are available. A Sleeve Bag option is available.

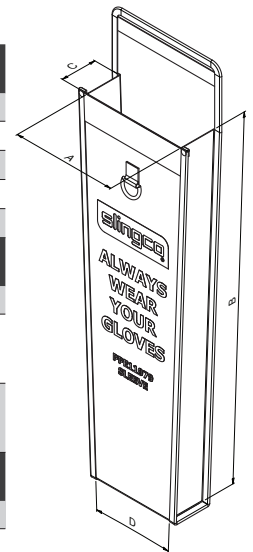

Slingco Part No.	Description	A - Width in (mm)	B - Height in (mm)	C - Depth in (mm)	Weight lb (kg)			
GLOVE BAGS								
PPE11973	12" Glove Bag	7.78 (200)	11.73 (298)	2.36 (60)	0.4 (0.18)			
PPE11974	14" Glove Bag	7.78 (200)	14.88 (378)	3.54 (90)	0.5 (0.23)			
PPE11975	16" Glove Bag	7.78 (200)	16.85 (428)	3.54 (90)	0.6 (0.27)			
PPE11976	18" Glove Bag	7.78 (200)	18.82 (478)	3.94 (100)	0.7 (0.32)			
Slingco Part No.	Description	Width in (mm)	Glove Depth in (mm)	Glove Height in (mm)	Sleeve Width in (mm)	Sleeve Depth in (mm)	Sleeve Height in (mm)	Weight lb (kg)
GLOVE & SLEEVE BAGS								
PPE11977	Compact Glove & Sleeve Bag	7.78 (200)	3.15 (80)	15.67 (398)	7.78 (200)	3.15 (80)	19.21 (488)	0.9 (0.41)
PPE11978	Full-Size Glove & Sleeve	7.78 (200)	3.94 (100)	18.82 (478)	7.78 (200)	1.76 (70)	29.45 (748)	1.4 (0.64)
Slingco Part No.	Description	A - Width Top in (mm)	D - Width Bottom in (mm)	C - Depth in (mm)	B - Height in (mm)	Weight lb (kg)		
SLEEVE BAGS								
PPE11979	Sleeve Bag	7.78 (200)	6.7 (170)	2.76 (70)	27.09 (688)	0.8 (0.36)		

Consistency.

When mission-critical jobs depend on it.

Products for cable and conductor installation, support and protection

HEAVY DUTY BANDING

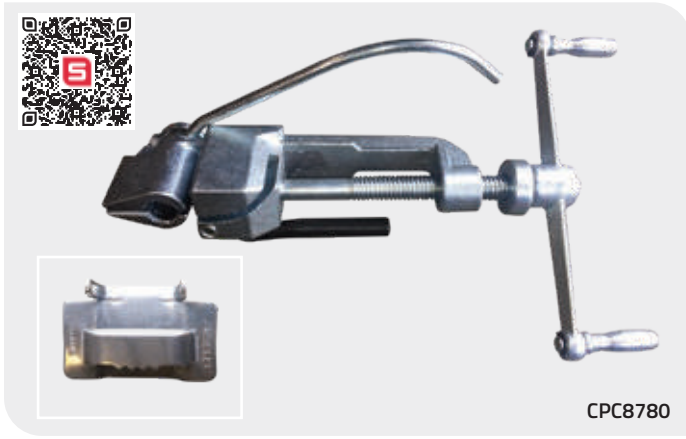

Banding tool					
Description					Slingco part no.
Operates on bands widths 3/4", 1", and 1-1/4" and thickness of 0.044". Featuring a built-in cutter and a sliding block assembly.					CPC8780
Bands					
Width	Thickness	Average break strength	Pack quantity	Weight	Slingco part no.
1-1/4"	0.044"	5500 lb	100' roll in CARDBOARD BOX PACKAGING	17.2 lb	CPC8745
Buckles					
Width	Pack quantity	Weight		Slingco part no.	
1-1/4"	25/Box	3.2 lb		CPC8747	

Use the Slingco 1-1/4" 201 Stainless Steel Banding system to secure cables and other items to structures and poles where extra strength hold is required. The Heavy Duty Banding Tool allows you to easily tighten and secure any length band loop.

Perfect for use with concrete utility poles. The extra width of this band provides stronger tensile strength than the 3/4" band as well

as a wider holding surface. Useful in many application environments including Utility, Marine and manufacturing where securely attaching cables, hoses or tubes onto a cylindrical object is needed. 100 ft. band roll comes in easy to stack and store cardboard box.

Giant buckles are made of 201 Stainless Steel and designed for use with 1-1/4" wide bands.

POLE BAND SYSTEM



The Slingco Pole Band System includes bolt clamps and mounting plates and 3/4" or 1-1/4" banding. Packages with different band lengths make this system flexible for varying pole sizes. Just measure the circumference of the pole and add a minimum of 6" and select the next size up. Securely mount hardware to cylindrical or square wooden, metal or concrete poles.

The system includes aluminium hardware extrusions, bolt hardware and pre-cut lengths of stainless steel banding. The system is easy to attach and tighten onto poles. The optional mounting plates allow quick attachment of hardware.

Extrusions and mounting plates available separately for use with rolls of banding cut to length in the field.



Slingco Part No.	Description	Pack Quantity	Pre-Cut Band Length		Band Width	
			in	mm	in	mm
PRE-ASSEMBLED EXTRUSIONS AND BANDING						
ZPC10646-48	Two extrusions and pre-cut band	12	48	1,219	0.75	19
ZPC10646-72	Two extrusions and pre-cut band	12	72	1,829	0.75	19
ZPC10647-48	Two extrusions and pre-cut band	12	48	1,219	1.25	31.75
ZPC10647-72	Two extrusions and pre-cut band	12	72	1,829	1.25	31.75
BOLT CLAMPS AND MOUNTING PLATES						
ZPC10646	0.75" (19 mm) Bolt Clamp	12	N/A	N/A	0.75	19
ZPC10647	1.25" (31.75 mm) Bolt Clamp	12	N/A	N/A	1.25	31.75
ZPC10648	Mounting Plate with 2" (50.8 mm) Bolt	12	N/A	N/A	0.75 or 1.25	19 or 31.75
ZPC10910	Mounting Plate with 3" (76.2 mm) Bolt	12	N/A	N/A	0.75 or 1.25	19 or 31.75
Slingco Part No.	Description	Pack Quantity	Pre-Cut Band Length		Band Width	
			in	mm	in	mm
BANDING (100 FT ROLLS)						
CPC8743	201 SS banding	100 ft in BOX	N/A	N/A	0.75	19
CPC8744	201 SS banding	100 ft in PLASTIC TOTE	N/A	N/A	0.75	19
CPC8745	201 SS banding	100 ft in BOX	N/A	N/A	1.25	31.75

LIGHT DUTY BANDING



Banding tool					
Description					Slingco part no.
Operates on band widths 1/4" to 3/4" and thickness up to 0.030". Tool has a built in cutter with PVC coated handle for comfort and sliding block assembly with spring loaded lever.					CPC8748
Bands					
Width	Thickness	Avg break strength	Pack quantity	Weight	Slingco part no.
3/4"	0.030"	2250 lb	100' roll - Cardboard Box	7.7 lb	CPC8743
3/4"	0.030"	2250 lb	100' roll - Red Plastic Tote	7.7 lb	CPC8744
1/2"	0.030"	1200 lb	100' roll - Cardboard Box	5.1 lb	CPC08325
1/2"	0.030"	1200 lb	100' roll - Blue Plastic Tote	5.9 lb	CPC08326
Buckles					
Width	Pack quantity		Weight		Slingco part no.
3/4"	100/Box		3.7 lb		CPC8746
1/2"	100/Box		2.5 lb		CPC08327

Use Slingco 3/4" wide 201 Stainless Steel, or the 1/2" wide 316 Stainless Steel, banding system to secure cables and other items to Utility poles, Light stands or other structures. The Light Duty Banding Tool allows you to easily tighten and secure any length band loop.

Slingco offers rolls of 3/4" and 1/2" wide banding material in 100 foot lengths. These 100 foot band rolls come in two convenient

packages – standard stack-and-store cardboard packaging, or an easy to carry red plastic tote for the 3/4" and a blue plastic tote for the 1/2".

The buckles used to secure these bands are made of 201 Stainless Steel and designed for 3/4" width bands, and 316 Stainless Steel designed for 1/2" bands.



HOLD DOWN WEIGHTS



Slingco's Hold Down Weights for transmission work are made from ductile cast iron with corrosion resistant zinc rich organic paint finish. 1" center through-hole rod mounting design for easy and secure deployment.

Slingco Part No.	Weight (lb)	Dimensions (in)
HMI5126	67	7.5 Ø x 6
HMI5127	100	9 Ø x 6

POLE STAPLES



Slingco Staples are used to securely hold grounding and bonding wires while insulating the wire from the staple. The insulation minimises TV and Radio Frequency Interference by preventing sparks. The insulator ensures that current cannot flow into the staple that could cause fires on the pole. The insulator also acts as a barrier to corrosion caused by contact with ground wires.

- Securely hold grounding and bonding wires
- Insulated inserts
- Barbed and non-barbed styles

Slingco Part No.	Description	For Use With Wire
ZMI6326	30mm (1.5") x 6.35mm (0.25") x 3.75mm (0.148") Galvanised barbed wood staple with TVI insulator	#6, #8 & #10 solid CU wire
ZMI6327	50.8mm (2") x 14.3mm (9/16") x 6.35mm (0.25") Galvanised bonding wire staple with TVI insulator	#4 CU wire

POLE LINE SUSPENSION CLAMPS



Slingco Suspension Conductor Clamps provide safe and quick installation and removal of the conductor when attached to the insulator. A single fastener fully opens and closes the jaw. The clamps come in a variety of sizes to accommodate conductors from 0.16 to 1.50 inch diameter, and loadings of up to 18,000 lbs. To prevent loss, all moving parts of the clamps are captive. Suitable for hot line work.

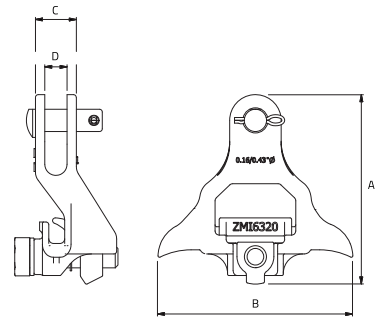

Depending on size, the clamps are either made from heat treated aluminium alloy 356-T6 or ductile iron 60-45-15 and hot dip galvanised for corrosion resistance.

Slingco Part No.	Range (in)	Material	A (in)	B (in)	C (in)	D (in)	Load (lb)
ZMI6320	0.16 - 0.43	Ductile iron	5.36	5.51	1.16	0.63	10,000
ZMI6321	0.30 - 0.70	Ductile iron	8.03	6.34	1.38	0.63	18,000
ZMI6322	0.50 - 0.687	Aluminium alloy 356-T6	6.22	6.89	1.61	0.63	12,000
ZMI6323	0.68 - 1.00	Aluminium alloy 356-T6	8.37	6.89	1.73	0.63	12,000
ZMI6324	1.00 - 1.313	Aluminium alloy 356-T6	9.53	6.97	1.74	0.63	12,000

Be informed. Be safe.

YOUR QUICK ACCESS GUIDE

At Slingco we're obsessed with quality and safety. And to that end, keeping you informed is key. We make finding information for our products quick and easy. You'll find QR codes on products so viewing manuals is simple while in the field with your mobile device.

Don't hesitate to contact our network of distributors or Slingco directly for information. We're here to help!



View our complete product range at slingcoamerica.com/products/

See all our manual and brochure downloads at slingcoamerica.com/resources/



Downloadable product instruction manuals and safety guides ensure you get the best from Slingco products while staying safe.



Scan the QR code to see our growing collection of online manuals.



ANCHOR BUSTER



Slingco Part No.	Description	Qty
SAE14487	Anchor Buster	1
SPARE PARTS		
SAN12680	Replacement Anchor Busting Tamping Head	1
SAE14788	Replacement hardware	1

Built to withstand heavy-duty field use, the Slingco Anchor Buster is a 10-foot expanding and tamping bar designed to bust open expanding anchors and serves as a tamping tool to pack dirt back into place.

Made from rugged materials and tested for repeat impact, the Anchor Buster is a reliable, manual solution for anchoring and tamping tasks where precision and strength are required.

ANCHOR ROD PULLING EYE



The Slingco Anchor Rod Pulling Eye installs on 0.5" to 1.25" anchor rods and is used in conjunction with hoist to tension and install pole guy wires. Attach guy wire to ground anchors safely.

Slingco Part No.	Description	Capacity		Load rating		Weight	
		in	mm	lb	kg	lb	kg
SAE12540	Anchor Rod Pulling Eye	0.5 - 1.25	12.7 - 31.7	6,000	2721	5.3	2.4

POLE LIGHT KIT



Slingco's 360 degree, high visibility Pole Light Kit includes heavy duty frame, ratchet strap, two flags, two 'D' size batteries, and a 360 degree LED pole light with two settings (flash and solid). Slingco recommends that you comply with all DOT transportation regulations for your state. This product is intended to be temporary. Inspect item before each use for wear, tear, or damage of any kind.

The Slingco Pole Light Kit has a QR code on the product so its manual is always available.

- | | |
|--|--|
| Features: | Available spares include: |
| <ul style="list-style-type: none"> ■ Lumens: 15,000 MCD | <ul style="list-style-type: none"> ■ Flags (in pairs): TPE12579 ■ Ratchet straps: TPE12670 ■ Light (Red): TPE12589 ■ Light (Amber): TPE12409 |



Slingco Part No.	Description
TPE12606-A	Pole Light Kit with AMBER light
TPE12606-R	Pole Light Kit with RED light
TPE12606-2F	No Light, w/2 Flags
TPE12606-3F	No Light, w/3 Flags
SPARE PARTS	
TPE12409	AMBER Light for pole light kit
TPE12589	RED Light for pole light kit
TPE12579	Flags (pair)
TPE12670	Ratchet straps

10K DRIVE WRENCH ASSEMBLY

EFFICIENT INSTALLATION OF SCREW ANCHORS

Drive Wrench System for installation of screw anchors. Component and options include:

- Orange Drive Wrench (#SAE09639)
- Yellow Drive Wrench (#SAE08666)
- Square Shank Anchor Tool (#SAE11132)
- Drive Wrench Lock (#SAE10425)
- 2.5 in Hex Kelly Bar Adapter (#SAE10486)
- 2.625 in Hex Kelly Bar Adapter (#SAE10427)
- 1.5 in Square Shank Bolted Assembly (#SAE13513)

Slingco's 10k Drive Wrench Assembly is a tool system for the installation of screw anchors.

Designed to connect the square anchor of a drive motor or screw anchor to the hexagonal Kelly Bar of a bucket truck. System options include Drive Wrenches to suit different sized anchor rods; a Drive Wrench lock; two Kelly Bar Adapters to fit the most common drive bar dimensions (2.5 in and 2.625 in) and square shank adapter and tool assembly.

The Drive Wrench Lock attaches to the Kelly Bar Adapter and makes the installation of the Anchor Rod much easier. The three position rings of the lock assembly ensure easy capture of the Drive Wrench and Anchor Rod, holding them securely while under torque and releasing them when needed.

The Drive Wrenches are designed to allow Anchor Rods to telescope inside, and secure to, the Drive Wrench Lock. The Drive Wrench transfers the torque from the Drive motor to the Screw Anchor, and are rated to 10,000 ft-lb.

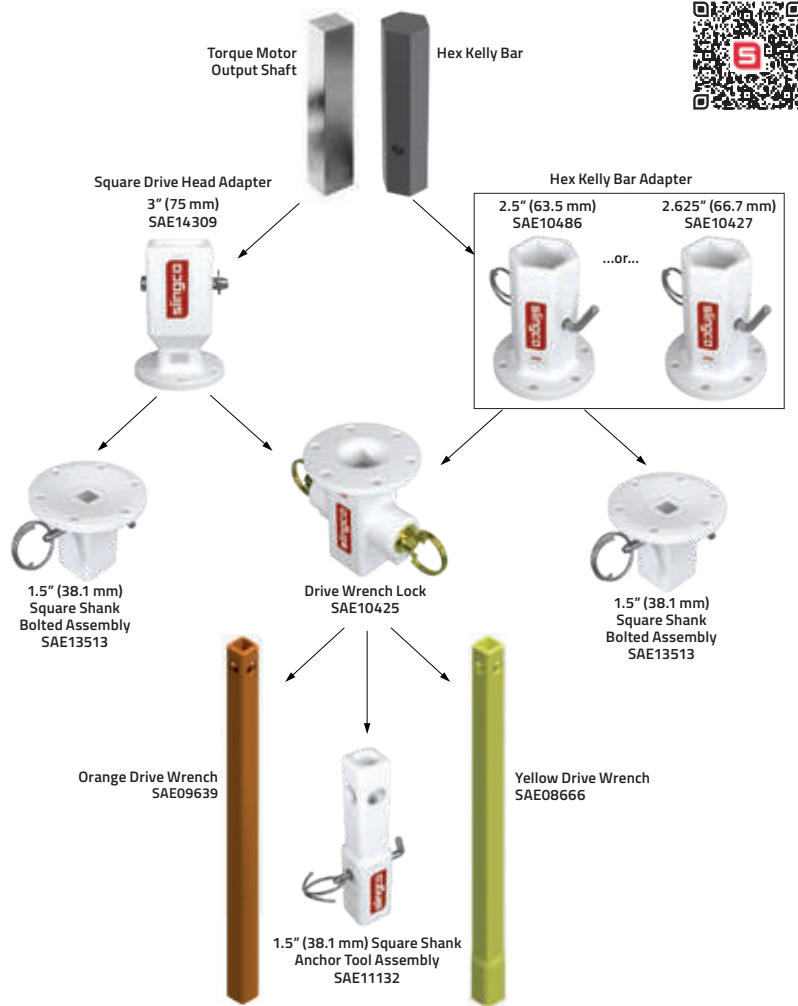

HEX KELLY BAR ADAPTERS



Slingco's Hex Kelly Bar Adapters are a key component in the Drive Wrench Assembly. The adapters are used to connect the Drive Wrench Lock Assembly to the Kelly Bar of the bucket truck. There are two versions available which fit the most common drive bar dimensions.

Slingco Part No.	Kelly Bar Shape	Adapter dimensions						Weight each	
		X		Y		Z		lb	kg
		in	mm	in	mm	in	mm		
SAE10486	HEX	2.5	63.5	4.25	108	8.25	210	16.3	7.39
SAE10427	HEX	2.625	66.7	4.25	108	8.25	210	16.7	7.57

DRIVE WRENCH LOCK ASSEMBLY



Slingco's Drive Wrench Lock Assembly attaches to the adapter and makes the installation of the anchor rod much easier. The three-position rings allow for easy capture of the Drive Wrench and the Anchor Rod, holding them securely while under torque, and releasing each when needed.

Slingco Part No.	Description	Weight	
		lb	kg
SAE10425	Drive Lock Assembly	18.4	8.35
SAE13513	1-1/2" Square Shank Bolted Assembly	12.3	5.58

SQUARE HEAD ADAPTER

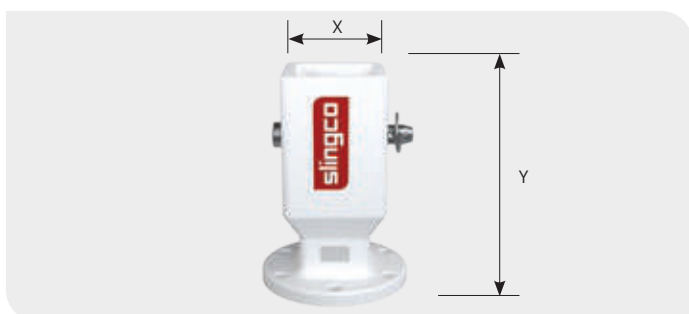

Slingco's Square Head Kelly Bar Adapters are a key component in the Drive Wrench Assembly. The adapters are used to connect the Drive Wrench Lock Assembly to a square torque motor output shaft.

Slingco Part No.	Kelly Bar Shape	Description	Adapter dimensions				Weight	
			X		Y		lb	kg
			in	mm	in	mm		
SAE14309	SQU	76 x 76 mm Square Head Adapter	3	76	9.4	240	16.5	7.5

DRIVE WRENCHES



Slingco's Drive Wrenches are designed to allow anchor rods to telescope inside them, and securing to the Drive Wrench Lock Assembly. The Drive Wrench transfers the torque from the drive motor to the screw anchor. Rated to 10,000 ft-lb of torque, Slingco's Drive Wrenches are tough and can handle anchor installs in tough environments.

Slingco Part No.	Description	Hub Size		Shaft Size	
		in	mm	in	mm
SAE09639	10,000ft-lb Orange Drive Wrench	2.25	57	1.375	35
SAE08666	10,000ft-lb Yellow Drive Wrench	2.5	63.5	1.5	38

Drive Wrench weight: 57 lb (28.85 kg)

Slingco Part No.	Description	Weight	
		lb	kg
SAE11132	7,000ft-lb 1-1/2" Square Shank Anchor Tool Assembly	11.4	5.17

POLE PULLER



Slingco's Pole Puller is a must have to comply with today's safe working practices, reducing the potential for boom damage and greatly reducing the potential of personal injury.

The Pole Puller is easily assembled and disassembled. The Standard Pole Puller System is composed of four pieces and the Deluxe System six pieces. These configurations make the Slingco Pole Puller easy to handle and lighter weight than typical units on the market.

The back plate weldment has angled teeth to increase hold on the pole during extraction. Slingco's Pole Puller offers a low point of attachment making it easy to remove even broken or cut poles. Convenient handles on the pole puller body make inserting over cylinder easy and pinch-free.

The Slingco Deluxe Pole Puller system includes the Pole Puller Pad and Back Plate Weldment. The Pole Puller Pad has studs which keep the Base Plate in the optimum position when pulling poles.



Slingco Part No.	Description	Max. Operating Pressure PSI	Recommended Flow Rate GPM	Lift at Max. Pressure		System Total Weight	
				lb	kg	lb	kg
TPE09386	Deluxe Pole Puller System	2,800	4 – 8	50,120	22,734	157	71.2

DELUXE Pole Puller System consists of: hydraulic cylinder*, chain, base weldment, swivel assembly PLUS back plate weldment, and pole puller pad.
*Hydraulic cylinder comes with flush face fittings installed.

TPE10551	Standard Pole Puller System	2,800	4 – 8	50,120	22,734	128	58
----------	-----------------------------	-------	-------	--------	--------	-----	----

STANDARD Pole Puller System consists of: hydraulic cylinder*, chain, base weldment, swivel assembly.
*Hydraulic cylinder comes with flush face fittings installed.

Slingco Part No.	Description	Weight	
		lb	kg
TPE09378	Pole Puller Pad	23	10.43
TPE09367	Back Plate Weldment	6	2.72
TPE09371	Pole Puller Chain	14	6.4
TPE10552	Swivel Weldment Assembly	35	15.9
TPE10491	Hydraulic Cylinder	57	25.9
TPE11999	Base Weldment	22	10

NOTE: See Pole Puller manual for complete parts breakout.

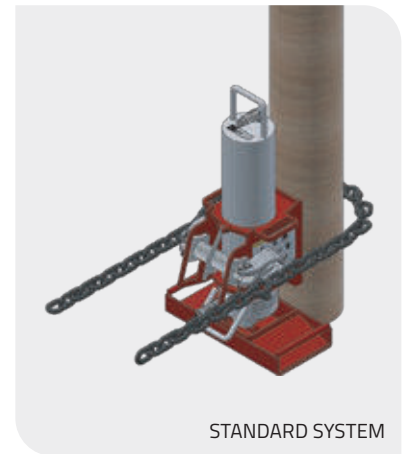

POLE STAND



TPE09682

Slingco's Pole Stands are lightweight and compact making them easy to place, remove, and store on your truck or jobsite. The support leg's swing-and-lock design make moving and storing the Slingco Pole Stand a breeze. The swing lock captures the legs in closed or open position for added safety.

- Lightweight and compact
- Quick swing-and-lock legs
- Positions poles for safe and comfortable framing

The Pole Stand positions the pole at an optimal height for easy and safe framing. The Standard Pole Stand's capacity of 9,000 lb makes it capable of handling the majority of wood distribution poles. For larger poles the Large Pole Stand has a capacity of 12,500 lb. The curved cradle allows for safe rotation of poles for proper framing positioning.

The Pole Stand's high visibility and durability make it a proven choice for any work location or environment.

Slingco Part No.	Description	Capacity		Height		Width		Weight	
		lb	kg	in	cm	in	cm	lb	kg
TPE09682	Pole Stand	9,000	4,082	23.75	60.33	30	76.2	32	14.5
TPE13932	Large Pole Stand	12,500	5,670	23.18	58.88	30.6	12	34.6	15.7

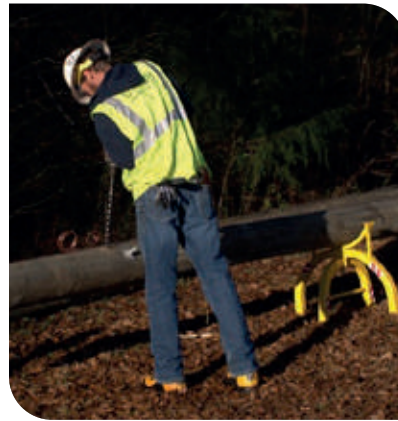

TPE13932

DIRT TARPS



Slingco's range of heavy-duty, re-usable Dirt Tarps have been created with safety in mind. Keeping workers out of awkward, injury-prone positions is better for their long-term health and the company's bottom line. Dirt Tarps have become a must-have product at utility construction sites. You can find Slingco Dirt Tarps being used at pole change-outs, transformer terminations, pedestals, as well as underground gas, telephone, and other underground utility applications.

In fact, with the ability to move crushed rock, sand, dirt, damp cement, dig spoils, and other contaminated soil, there are few reasons NOT to have a Slingco Dirt Tarp on the project!

Slingco Part No.	Tarp Dimensions		Maximum Capacity	
	ft	mm	lb	kg
ZLD10015	10 x 10	3,048 x 3,048	5,000	2,267
ZLD10016	8 x 8	2,438 x 2,438	5,000	2,267
ZLD10793	7 x 7	2,133 x 2,133	4,000	1,814
ZLD10792	6 x 6	1,828 x 1,828	4,000	1,814

DISTRIBUTION STRINGING BLOCKS & ACCESSORIES

LIGHTWEIGHT, RELIABLE AND VERSATILE

DISTRIBUTION STRINGING BLOCKS

- Distribution Stringing Blocks
- Crossarm Brackets
- Y-Ball and U-Ball Clevises
- Insulator Bracket

Distribution Stringing Blocks

Slingco offers two lightweight, rugged, reliable and durable Aluminium Distribution Stringing blocks.

Used in conjunction with purpose-designed accessories, the Slingco 7" Blocks have proven extremely popular with utility operators and their contractors for the exceptional versatility they offer in terms of installation applications and locations.

Their low-friction bearings deliver high efficiency, which helps to maximise stringing distances while minimizing pulling tensions and reducing loads on stringing equipment.



ZAB4004



ZAB4344

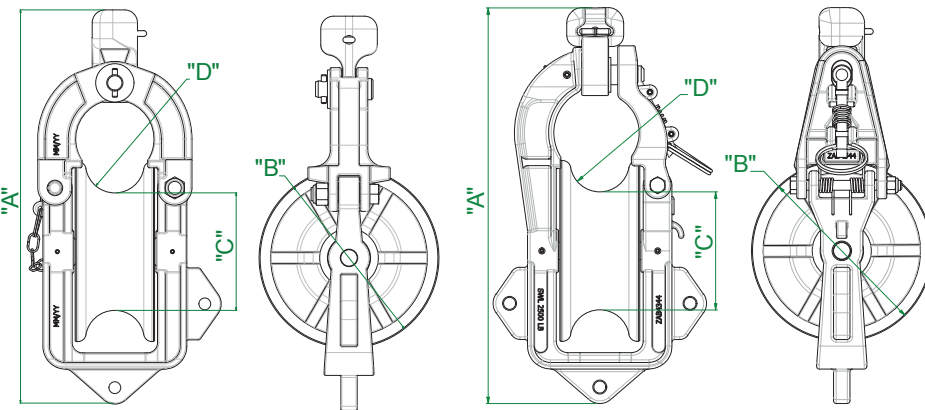

ZAB4004

ZAB4344

Slingco Part No.	Description	Weight		WLL		Height "A"		Sheave Diameter "B"		Bottom of Groove "C"		Groove Radius "D"	
		lb	kg	lb	kg	in	mm	in	mm	in	mm	in	mm
ZAB4004	7" Pin Gate Aluminium Distribution Block	8.3	3.76	2,500	1,134	15.125	384.2	7	177.8	4.5	114.3	2.25	57.15
ZAB4344	7" Spring Gate Aluminium Distribution Block	9.2	4.17	2,500	1,134	15.344	389.74	7	177.8	4.5	114.3	2.25	57.15

CROSSARM BRACKETS



ZMI10017



ZMI10018

CROSSARM RATCHET STRAP BRACKET



ZMI14338

INSULATOR BRACKETS



ZMI14345



ZMI14346

Y BALL CLEVIS



CSB09094

U BALL CLEVIS



CSB09095

Crossarm Brackets

Slingco Crossarm Brackets are designed for easy attachment of distribution blocks to crossarms. Securely mount distribution blocks to crossarms at three convenient angles based upon the needs of your pull. Quick release pin for attachment of distribution block. Fits most crossarm sizes.

Two styles available: full frame (ZMI10018) and partial frame (ZMI10017).

Crossarm Ratchet Strap Bracket

Used in conjunction with Slingco's 7" Stringing Blocks, the Crossarm Ratchet Strap Bracket (ZMI14338) can be mounted on wooden, fibreglass or composite crossarms, as well as concrete, wood, or steel poles. This versatile crossarm bracket with ratchet strap allows stringing blocks to be mounted horizontally or vertically.

Strap length is 60" (1500 mm), with a WLL of 2500 lb (1,133 kg).

Insulator Bracket

Used in conjunction with Slingco 7" Stringing Blocks, the Slingco Insulator Bracket with bolt (ZMI14345) or handle (ZMI14346) fit insulators with a neck range of 2-1/8" – 3-1/2". The Slingco Insulator Brackets have a WLL of 2,500 lb (1,133 kg) in the vertical direction and 1,500 lb (680 kg) in the horizontal direction.

Slingco Part No.	Description	WLL	
		lb	kg
ZMI10017	Partial Frame Crossarm Bracket	2,500	1,133
ZMI10018	Full Frame Crossarm Bracket	2,500	1,133
ZMI14338	Crossarm Ratchet Strap Bracket	2,500	1,133
ZMI14345	Insulator Bracket with Bolt	2,500	1,133
ZMI14346	Insulator Bracket with Handle	2,500	1,133
CSB09094	Y Ball Clevis	30,000	13,600
CSB09095	U Ball Clevis	30,000	13,600

GUY WIRE DISPENSER



LARGE

STANDARD

Slingco's Guy Wire Dispenser saves linemen time, effort, and keeps them safe. Efficiently dispense and take up excess guy wire from a permanently mounted source. Operation of the dispenser is kept smooth thanks to the high load sealed ball bearing. The Guy Wire Dispenser is constructed of high strength steel coated in a durable black and yellow finish to enable the unit to endure the harsh outdoor environment.

Easy to operate release knobs allow for quick and easy loading and unloading.

- Handles Guy Wire OD up to 1/2"
- Permanently mounts to truck or other surface
- Smooth pay-out operation thanks to high load sealed bearings

Slingco Part No.	Max. Wire Size		Coil Width Capacity		Coil Diameter Range		Weight	
	in	mm	in	mm	in	mm	lb	kg
ZWM09207	0.5	12.7	4.75	120	22 - 31	559 - 787	45	20.5
ZWM12496	0.5	12.7	8.75	222.25	32 - 36	813 - 914	54	24.5

REPAIR KIT

ZWM09741	Guy Wire Knob Replacement Kit - contains all parts needed to replace securement knobs.
----------	--

TRIPLEX DISPENSER



The Slingco Triplex Dispenser is designed to be permanently mounted for the efficient dispensing of triplex. Slingco's Triplex Dispenser is designed to keep linemen safe while saving time and effort.

Constructed of high strength steel coated in a durable black and yellow finish allows the unit to endure the harsh outdoor environments. The high load sealed ball bearing keeps operation and rotation smooth.

Easily adjust break tension with a 3/4" wrench. Simple pull knob operation for loading of triplex coils.

Wire guide allows easy payout and rewinding of triplex.

Slingco Part No.	Coil OUTSIDE Diameter Range		Coil INSIDE Diameter Range		Coil Width Capacity		Weight	
	in	mm	in	cm	in	cm	lb	kg
ZWM09903	26 - 32	66 - 81.3	14 - 20	35.5 - 50.8	10.25	26	54	24.5

REPAIR KIT

ZWM12698	Repair Kit - contains parts needed to replace securement knobs
----------	--

Availability.
When and where it matters.

Products for cable and conductor installation, support and protection



REEL LIFTER



The Slingco Reel Lifter is a high capacity, compact unit that allows users in the construction industry to safely load, transport, and dispense wire and/or cable on-site. It is also used in many industrial applications to make moving and relocating reels in a warehouse easy. Now a task that normally used a team of three or four people can be done with just one, allowing the crew to operate more efficiently!

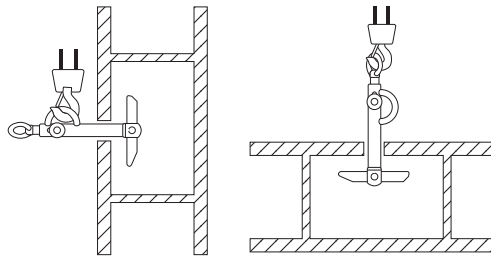

Makes handling large cable reels quick and easy, on-site or in warehouses.

- Rugged construction to lift and unpend reels
- Easy rotation to unroll cable
- Counterweighted bottom arm for easy insertion in reel
- Side flipping eye allows reels to be flipped into a non-rolling position
- Repair kits available
- Complies with ASME B30.20.1

Slingco Part No.	Arbor Hole min.		Arbor Hole max.		Capacity		Weight		Length	
	in	mm	in	mm	lb	kg	lb	kg	in	mm
REEL LIFTER										
ZLD08729	2	50.8	4	101.6	3,000	1,360	6.50	2.95	16.125	409.6
ZLD09186	3	76.2	6	152.4	5,000	2,268	14.50	6.58	21.125	536.6
ZLD10807	3.25	82.55	6	152.4	12,000	5,443	32.33	14.66	30.53	775.5
REEL LIFTER REPAIR KITS										
Repair kits come with extension springs, cable assemblies, and all necessary replacement cotter pins to replace the interior cable system.										
ZLD09708	3,000 lb (1,360 kg) Repair Kit for ZLD08729									
ZLD09707	5,000 lb (2,268 kg) Repair Kit for ZLD09186									

HAND LINE TOOLS



3" Hand Line Block - Screw Pin

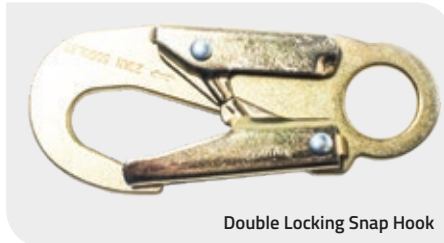

Double Locking Snap Hook



Hand Line Hook

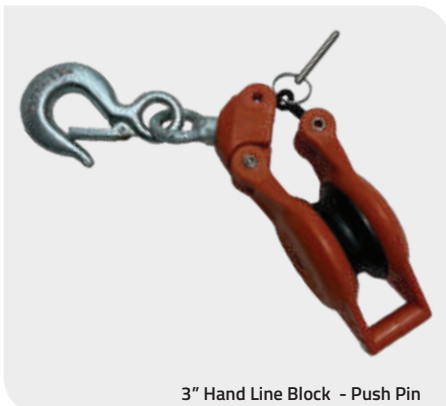

3" Hand Line Block - Push Pin



3" Hand Line Block - Meat Hook

Slingco's Hand Line Tools include a 3" (76.2mm) nylon fibreglass block, with a safe working load limit of 1,000 lb (453.59 kg), and a double locking snap with a safe working load limit of 5,000 lb (2267.96 kg).

Our 3" (76.2mm) Hand Line Block's sheave can accommodate a 5/8" (15.875 mm) diameter rope, and operates smoothly on the 0.5" (12.7 mm) diameter axle and swivel bearings. The side opening feature allows quick access to remove the hand line.

The Hand Line Hook is made of manganese bronze, and is made for use with 1/2" (12.7 mm) rope.

Slingco Part No.	Description	Working Load Limit	
		lb	kg
ZAB8725	3" Hand Line Block (Screw Pin)	1,000	454
ZAB8725-P	3" Hand Line Block (Push Pin)	1,000	454
ZAB8725-M	3" Hand Line Block (with Meat Hook)	1,000	454
HMI8556	Double Locking Snap Hook	5,000	2,268
HMI6502	Hand Line Hook	600	272

STRAP HOISTS

SPLICE, DEAD END, AND SAG LINES QUICKLY AND EFFICIENTLY

- ASME B.30.21 compliant
- 125% working load tested
- Interlocking pawl lever system
- Replacement parts readily available
- Hot stick operable version

Linemen use the Slingco Strap Hoist to splice, dead end, and sag lines. The Slingco Strap Hoist features an easy to operate pressure die cast drum for a professional look and smooth finish to minimise the risk of strap fraying.

The Hoist also features an interlocking pawl system with dual pawl springs for controlled tightening and releasing of the strap which ensures that the Hoist is engaged while in use. The fibreglass handle assembly colour matches to each coloured strap to ensure use of appropriate handle with correct hoist.

The straps are hi-viz bright green, blue, and yellow in colour for easy visibility and identification. Strap Hoists may be operated in single line or double line modes for capacity required.



The Strap Hoist has three operations: lift/pull, lower/release, and freewheeling. For information while in the field, use the QR code found on Slingco products to quickly reach the user manual as well as helpful safety information while mobile. All Strap Hoists comply with ASME B.30.21 standard and all units are tested to 125% of load.

2K STRAP HOIST

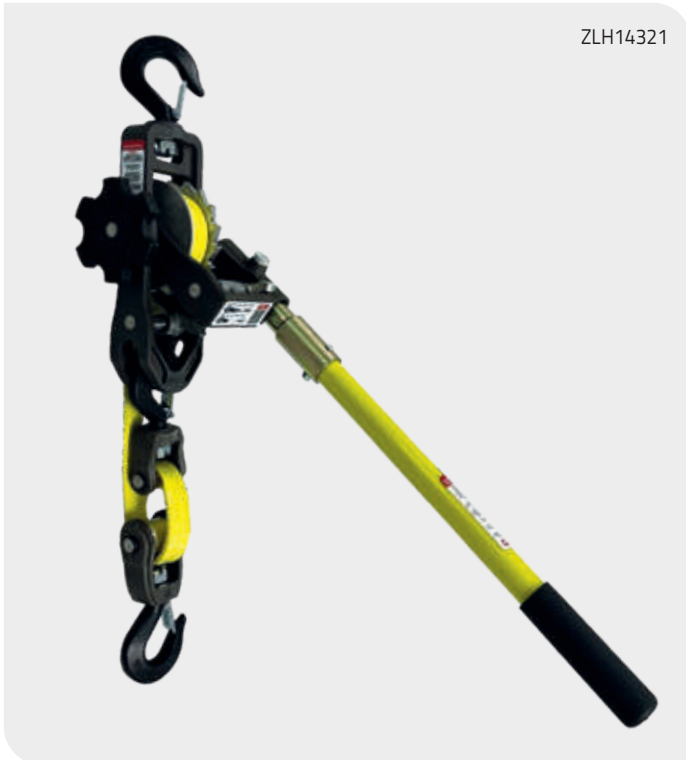

ZLH14321



ZLH14447



The Slingco 2K Strap Hoist features a hi-viz yellow strap for easy identification. In single line mode capacity is 1K. When used in double line mode capacity is 2K. The 2k Strap Hoist has a pressure die cast drum for professional look and smooth finish to minimise the risk of strap fraying. The Strap Hoist has three operating positions: lift/pull, lower/release, and freewheeling. For information while in the field, use the QR code on Slingco products to quickly reach manual and helpful information on your mobile.

Slingco Part No.	Type	SINGLE LINE							DOUBLE LINE								
		Capacity		Lift		Headroom			Capacity		Lift		Headroom			Tool weight	
		lb	kg	ft	m	in	mm	lb	kg	ft	m	in	mm	lb	kg		
ZLH14321	Standard	1,000	453.6	9	2.7	15.5	393.7	2,000	907	4.25	1.3	18.5	469.9	8.46	3.84		
ZLH14447	Hot stick operated	1,000	453.6	9	2.7	15.5	393.7	2,000	907	4.25	1.3	18.5	469.9	9.04	4.10		

3K STRAP HOIST



ZLH10504

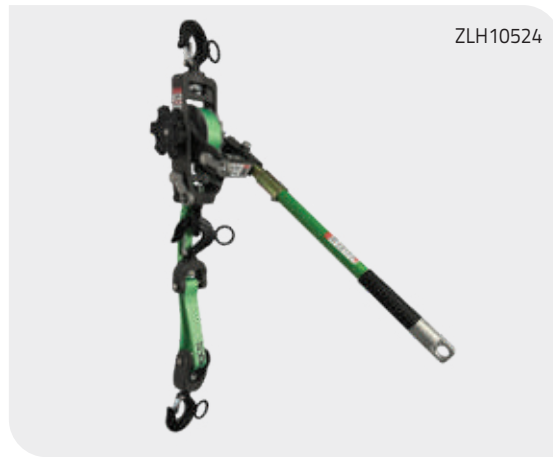

ZLH10524



The Slingco 3K Strap Hoist features a hi-viz green strap for easy identification. In single line mode capacity is 1.5K. When used in double line mode capacity is 3K. It has a pressure die cast drum for professional look and smooth finish to minimise the risk of strap fraying. The Strap Hoist has three operating positions: lift/pull, lower/release, and freewheeling.

Slingco Part No.	Type	SINGLE LINE						DOUBLE LINE						Tool weight	
		Capacity		Lift		Headroom		Capacity		Lift		Headroom			
		lb	kg	ft	m	in	mm	lb	kg	ft	m	in	mm	lb	kg
ZLH10504	Standard	1,500	680	9	2.7	17.5	444.5	3,000	1,360	4.25	1.3	22	558.8	11.25	5.1
ZLH10524	Hot stick operated	1,500	680	9	2.7	17.5	444.5	3,000	1,360	4.25	1.3	22	558.8	11.5	5.22

4K STRAP HOIST

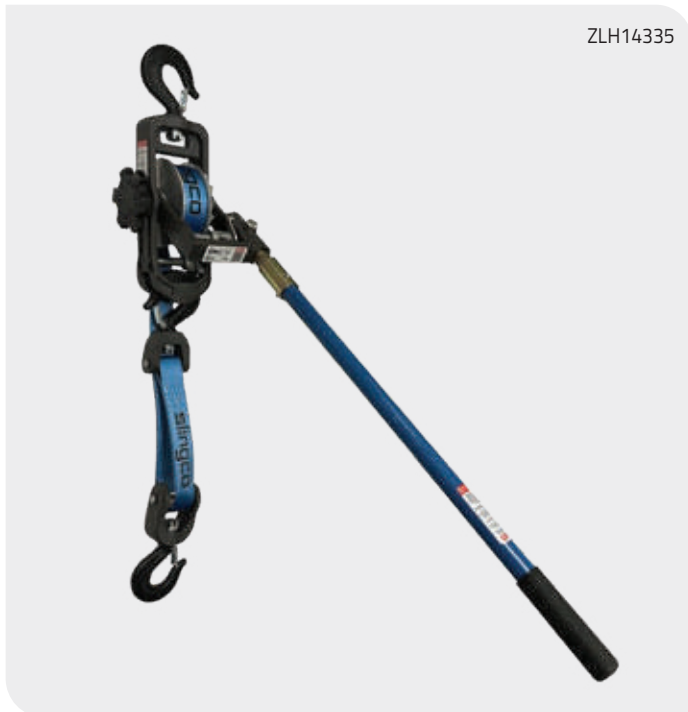

ZLH14335

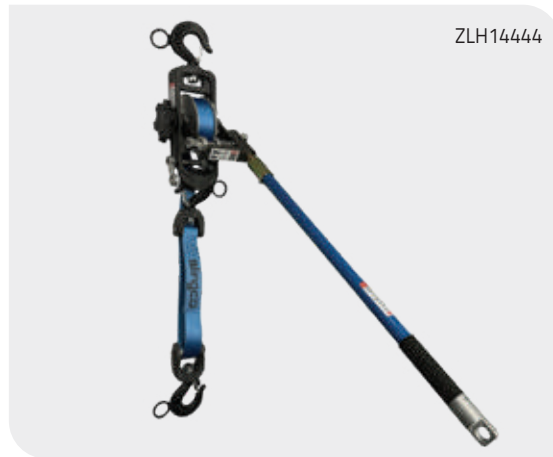

ZLH14444



The Slingco 4K Strap Hoist features a hi-viz blue strap for easy identification. In single line mode capacity is 2K. When used in double line mode capacity is 4K. The 4k Strap Hoist has a pressure die cast drum for professional look and smooth finish to minimise the risk of strap fraying. The Strap Hoist has three operating positions: lift/pull, lower/release, and freewheeling. Strap Hoists come in standard and hot stick operable versions.

Slingco Part No.	Type	SINGLE LINE						DOUBLE LINE						Tool weight	
		Capacity		Lift		Headroom		Capacity		Lift		Headroom			
		lb	kg	ft	m	in	mm	lb	kg	ft	m	in	mm	lb	kg
ZLH14335	Standard	2,000	907	11	3.4	16.5	419.1	4,000	1,814	5.5	1.7	22.5	571.5	14.28	6.48
ZLH14444	Hot stick operated	2,000	907	11	3.4	16.5	419.1	4,000	1,814	5.5	1.7	22.5	571.5	14.89	6.75

BRIDGE TYPE CABLE LAYING ROLLER



Made of steel with zinc plating for general purpose cable installation work in trenches or over rough surfaces. They are suitable for power, telecoms and utility installations, and can bridge existing cables or conduit in trenches or ducts.

The Compact Cable Roller is for use in narrow trenches and/or in confined areas. Contact Slingco if you have custom roller needs.

Bridge Type Cable Roller

Slingco Part No.	Base Footprint in (mm)	Height to top of roller in (mm)	Handle height in (mm)
ZGP2395	12 x 9.5 (305 x 240)	7.125 (180)	10 (255)

Compact Bridge Type Cable Laying Roller

Slingco Part No.	Base Footprint in (mm)	Height in (mm)	Max Cable Diameter in (mm)	Weight lb (kg)
ZGP8270	10.83 x 5.9 (275 x 150)	7 (180)	3.54 (90)	5.5 (2.5)

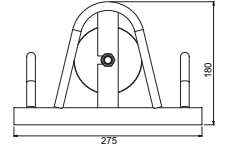
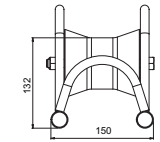
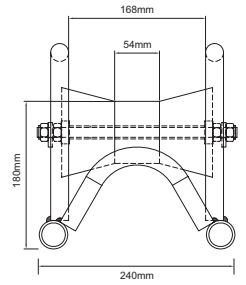

* Drawing measurements in mm

EDGE MOUNT MANHOLE LEAD-IN CABLE LAYING ROLLER (HEAVY DUTY)



The manhole cable roller leads the cable from the drum into the jointbox/manhole or the winch bond out of the manhole.

- Heavy duty tubular steel construction
- Suitable for cables up to 130mm
- Three x 0.11" x 4.33" diameter steel rollers fitted with sealed precision roller bearings
- Zinc plated
- Weight: 22.05 lb

* The Diablo Rollers can be substituted with a heavy gauge 3.5" tubular Steel Roller fitted oil impregnated maintenance free bushes for use with the heavier cables.

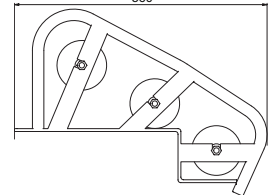
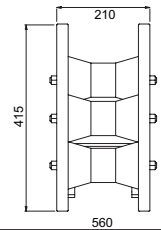

* Drawing measurements in mm

Slingco Part No.	Base Footprint in (mm)	Height in (mm)
ZGP8209	22 x 8.25 (560 x 210)	22 x 8.25 (415)

CABLE DRUM ROTATOR

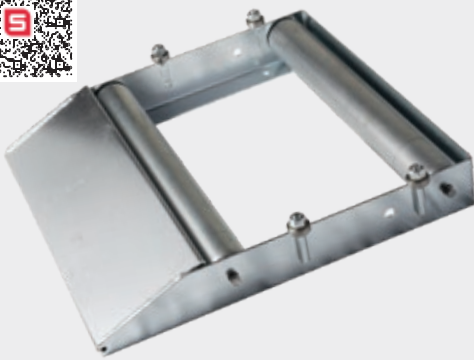

This is a compact light weight Cable Drum Rotator. Drums are simply rolled up the ramp on to the adjustable rollers to allow it to spin freely.

- Pressed steel construction
- Ideal for where space is limited.
- 2.36" diameter zinc plated rollers
- Sealed roller bearings fitted
- Spring loaded shafts for easy replacement/adjustment
- Capacity 440 lb
- Max / min drum size 31.5" / 11.81"
- Drum Width 17.72"
- Zinc plated finish
- Weight: 23.15 lb

Slingco Part No.	Base Footprint in (mm)	Height in (mm)	Max. Capacity lb (kg)
ZGP8267	19.68 x 20.66 (500 x 525)	4.72 (120)	440 (200)

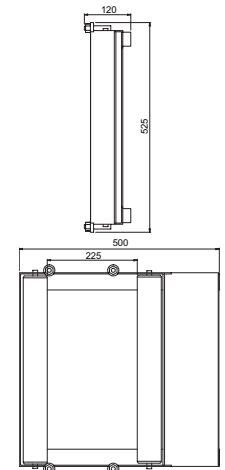

HEAVY DUTY STRAIGHT LINE CABLE LAYING ROLLER

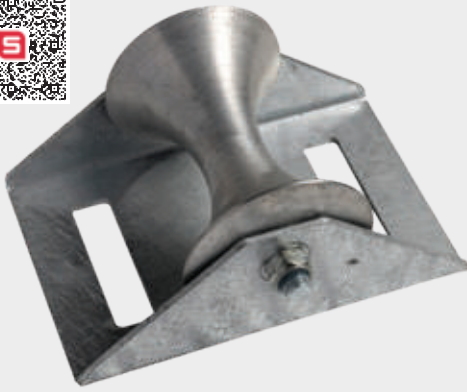

The diablo roller is machined with a 4.2" radius giving a maximum cable diameter capacity of 8.43".

- Heavy duty folded frame straight line roller
- Aluminium diablo roller
- Sealed roller bearing and 0.787" shaft
- Galvanised finish
- Weight : 15.43 lb

Slingco Part No.	Base Footprint in (mm)	Height in (mm)
ZGP8268	11.81 x 7.87 (300 x 200)	6.1 (155)

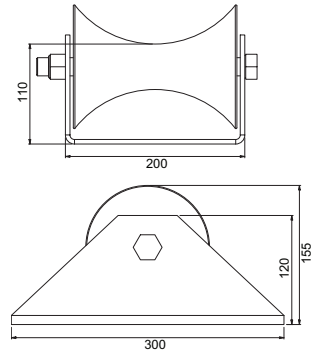

* Drawing measurements in mm

HEAVY DUTY TRIPLE CORNER CABLE LAYING ROLLER



This is a heavy duty corner cable roller for use in most cable laying applications. They can be used singularly or linked together using link pins to form a full bend. All products in the bend roller range have the same link points to facilitate various bend/roller configurations.

- Heavy duty corner roller made from tubular sections
- Three x 0.11" x 4.33" diameter large waisted steel rollers*
- Sealed roller bearing fitted
- Zinc plated finish
- Universal link pin mount positions
- Weight 18.75 lb

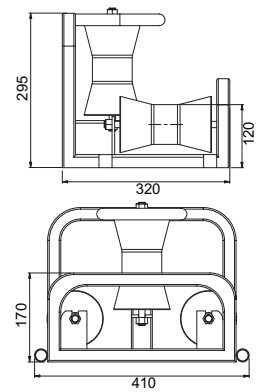

* Drawing measurements in mm

* The diablo rollers can be substituted with a heavy gauge 3.5" tubular steel roller fitted with oil impregnated maintenance free bushes.

Slingco Part No.	Base Footprint in (mm)	Height in (mm)
ZGP8269	16.14 x 12.6 (410 x 320)	11.61 (295)

EDGE MOUNT MANHOLE LEAD-IN CABLE LAYING ROLLER (LIGHT DUTY)



The manhole cable roller leads the cable from the drum into the vault/manhole or the winch bond out of the manhole. The roller has 2 hooks for location on the edge of the manhole.

- Heavy steel section construction
- 3" diameter aluminium roller*
- Fitted with oil-impregnated maintenance-free bushes
- Sealed precision roller bearings
- Zinc plated or powder coated finish
- Weight 6.6 lb

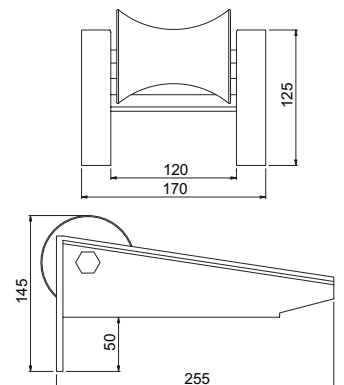

* Drawing measurements in mm

*The aluminium roller can be substituted with a solid steel roller when using wire winch bond thus preventing damage.

Slingco Part No.	Base Footprint in (mm)	Height in (mm)
ZGP8210	10 x 6.7 (255 x 170)	5.7 (145)

'V' TYPE LEAD IN CABLE LAYING ROLLERS

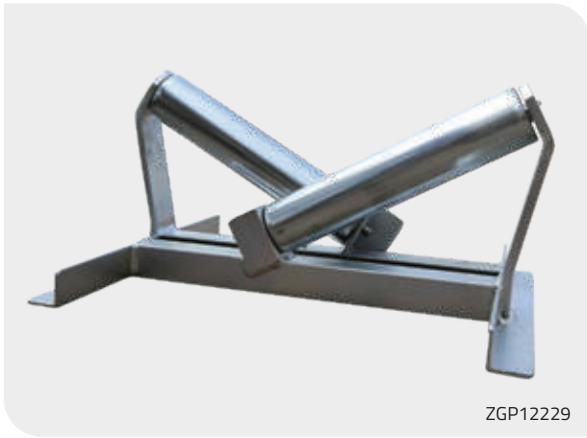

ZGP12229



ZGP12230

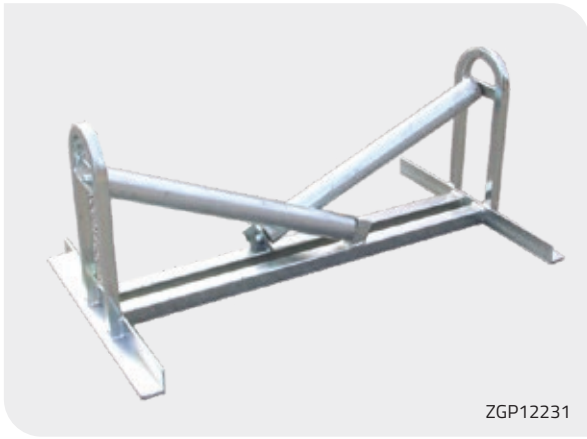

ZGP12231

The Slingco 'V' Style Cable Roller leads the cable from the drum into the trench, the design is such that cable is centralised prior to it being fed into the trench. This cable roller can also be used as a Pipe Roller.

Slingco Part No	Length		Width		Height		Special features
	in	mm	in	mm	in	mm	
ZGP12231	41.33	105	23.62	60	17.32	44	Fixed Shaft for heavy applications
ZGP12230	33.46	85	23.62	60	17.32	44	Spring Loaded Shafts for easy replacement
ZGP12229	19.69	50	15.75	40	9.84	25	Spring Loaded Shafts for easy replacement



Reliability.
When more is on the
line than just the job.

Products for cable and conductor
installation, support and protection



CABLE PULLING GRIPS AND CABLE SUPPORT GRIPS

ASSESSMENT OF SUITABILITY

There are many factors that must be taken into account when assessing the suitability of a cable grip for a proposed application and trying to calculate a safe working load.

These include:

- Size of cable grip in relation to size/shape of gripped object(s)
- Stability of object(s) when gripped
- Grip surface of object(s)
- Resistive force of object(s)
- Anticipated path of movement, including possible obstructions
- Approximate breaking strength of the cable grip
- Condition of cable grip
- Suitability and compatibility of any attachments used
- Environment / operating conditions
- Persons at risk

If you have any questions regarding suitability for any particular application please call the distributor who supplied the cable grip or our in-house Technical Department.

Please note: Slingco cable grips must be double steel banded securely before being pulled.

LATTICE DIMENSIONS

Lattice dimensions shown are as fitted to a nominal diameter of cable and prior 'free length' may be slightly longer than stated.

APPROXIMATE BREAK LOAD

This is the calculated average based on actual testing done by Slingco. Approximate break loads are quoted as a guide only.

TYPICAL CONFIGURATIONS

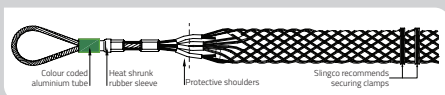

SAFE WORKING LOAD

Application load is normally calculated to be reduced by at least a factor of 5x the Approximate break load. Due to the wide variety of application parameters, the end user must apply a sensible safety factor to suit the safety requirements for the conditions of use.

The Safe Working Load (SWL) of a Slingco cable grip will depend on the Factor of Safety (FOS) applied to the Minimum Breaking Load.

FACTOR OF SAFETY (FOS)

Where the operational risk is considered to be normal, it is recommended that a FOS of 5 be applied, for a high risk operation a FOS of at least 10 should be considered. It is impossible to catalogue or guarantee a safety factor that will apply for all applications.

Approximate Break Loads stated on any certification, the recommended Factors of Safety, and any implied or stated fitness for purpose, are all only applicable when the cable grip is as new and unused.

A 20% variance in break loads must be allowed for when selecting a cable grip; a suitable swivel must be used if there is 'twist' in the cable.

Torsional stress must be dealt with when using grips for line pulls and wire splices. When twisting forces are present use a swivel that rotates under load to release torsional stress.

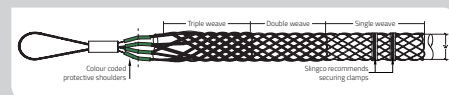

Cable Grip Safety Information

- Ensure that the cable grip mesh fits conductor correctly
 - Ensure that the conductor fits up to the mid-point of the protective shoulder
 - Clamp the ends of the cable grip when attaching the conductor. We recommend between 1¼" and 2¼" from the end of the cable grips
- SECURE CLAMPING MUST BE USED ON SLINGCO CABLE GRIPS**
- Never modify or attempt to repair any grip
 - Ensure proper maintenance of the cable grip. If in doubt call 01706 855558
 - Check the condition of the cable grip, and that it is the correct size for the intended application - do not exceed the rated capacity
 - Grips that are worn, bent or otherwise damaged should not be used
 - Grips are only to be used for temporary installations
 - Pulling devices should only be attached via the pulling eye
 - Cable grips must only be fitted and used by trained competent person(s)
 - Cable grips must not be used as primary lifting devices



SLINGCO CABLE GRIPS MUST NOT BE USED TO THEIR APPROXIMATE BREAKING STRENGTH. A SENSIBLE SAFETY FACTOR MUST ALWAYS BE USED. IF IN DOUBT CONTACT THE MANUFACTURER OR THE DISTRIBUTOR THAT SUPPLIED THE GRIP!

If you have any questions regarding suitability for any particular application please call 01706 855558



IMPORTANT TECHNICAL INFORMATION

SINGLE AND DOUBLE EYE CABLE GRIP INSTRUCTIONS

PLEASE NOTE: The condition of the cable grip should always be checked prior to use. The correct size of grip should always be used for the intended application. The rated capacity of the grip should never be exceeded. Grips that are worn, bent or otherwise damaged should not be used.



Select the correct grip for the diameter of the conductor.



Prior to use, the lattice at the end of the grip needs to be widened. This can be easily achieved by pressing the end of the grip against a hard surface, which causes the lattice to expand.



The grip should then be placed over the end of the conductor...



...and pushed over the conductor.



The grip then needs to be pushed along so that all the lattice is in contact with the conductor.



Once the cable grip is in place on the conductor, two clamps should be fitted to the end of the grip (as shown). We recommend between 1 ¼" (30mm) and 2 ¼" (55mm) away from the end of the cable grip.



Tape should then be wound around the end of the cable grip furthest away from the eye ends.



This will prevent the cable grip from snagging when in use.

LACE UP CABLE GRIP INSTRUCTIONS

PLEASE NOTE: The images shown here use double weave cable grips. When lacing single weave cable grips please use single wire lace; use double-laced for double weave cable grips; and use triple-laced for triple weave cable grips.



1 Start the lacing from the 'eye' end or anchoring end of the cable grip.



2 Thread the lace through the first two loops of the split and pull through until the laces are centered at this point.



3 Don't pull the lace too tight at this stage. Leave a space between adjoining loops roughly equal to the width of one diamond of the mesh.



4 Continue down the length of the cable grip. Try to maintain equal tension and equal spacing throughout as this leads to a more stable and equal grip.



5 As you continue down the length, pull the open sides of the grip as wide apart as required.



6 Try to achieve an even and neat lace-up as this assists with the strength of the grip when pulling.



7 Finally, tie the ends of the lace once or twice round the end of the cable grip twisting the ends together securely. Excess lace can be cut off.

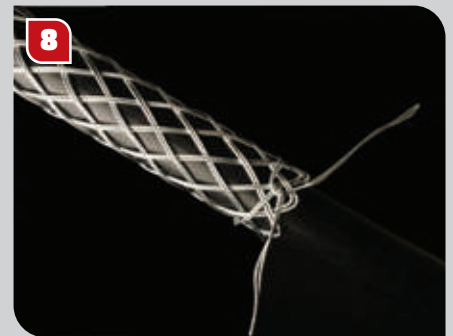

8 Add any additional support as required – banding is recommended. The Slingco cable grip is now ready to use.

 **+44 [0]1706 855558**

 sales@slingco.com

 [slingco.com](https://www.slingco.com)



Slingco Limited, Gateway Business Park, New Hall Hey Road, Rawtenstall, BB4 6JG, England · Tel: +44 [0]1706 855558 · sales@slingco.com

This document is for marketing purposes only. The information contained herein is presented as general information and no representation or warranty is expressly or impliedly given as to its accuracy, completeness or correctness. It does not constitute part of a legal offer or contract. For technical specifications, please contact Slingco Limited.

March 2026 - v1.2