



PRODUCT MANUAL

REEL LIFTER

MOVE, FLIP & DISPENSE LARGE REELS OF CABLE & WIRE QUICKLY AND EASILY



Makes handling large cable reels quick and easy, on-site or in warehouses.

- Rugged construction to lift and unpend reels
- Easy rotation to unroll cable
- Counterweighted bottom arm for easy insertion in reel
- Side flipping eye allows reels to be flipped into a non-rolling position
- Repair kits available
- Complies with ASME B30.20.1

The Slingco Reel Lifter is a high capacity, compact unit that allows users in the utility construction industry to safely load, transport, and dispense wire and/or cable on-site. It is also used in many industrial applications to make moving and relocating reels in a warehouse easy. Now a task that normally used a team of three or four people can be done with just one, allowing the crew to operate more efficiently!

Slingco Part No.	Arbor Hole min.		Arbor Hole max.		Capacity		Weight		Length	
	in	mm	in	mm	lb	kg	lb	kg	in	mm
REEL LIFTER										
ZLD08729	2	51	4	102	3,000	1,360	6.50	2.95	16.125	410
ZLD09186	3	76	6	152	5,000	2,267	14.50	6.58	21.125	537
ZLD10807	3.25	83	6	152	12,000	5,443	32.33	14.66	30.53	775
REEL LIFTER REPAIR KITS										
Factory repair kits with extension springs, cable assemblies and all necessary pins for replacement of the interior cable system.										
ZLD09708	1,360 kg (3,000 lb) factory repair kit. Suitable for ZLD08729.									
ZLD09707	2,267 kg (5,000 lb) factory repair kit. Suitable for ZLD09186.									

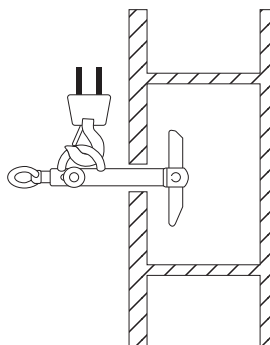

FLIPPING CONFIGURATION

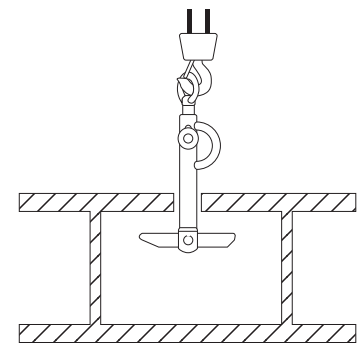

LIFTING CONFIGURATION

FOR ANY ENQUIRIES CALL TODAY ON

+44 [0]1706 855558

Slingco Limited

Gateway Business Park, New Hall Hey Road, Rawtenstall, BB4 6JG, England
Tel: +44 [0]1706 855558 · Fax: +44 [0]1706 855559
sales@slingco.com



slingco.com