

POLE LINE SUSPENSION CLAMPS

⚠ WARNING

Cancer and Reproductive Harm: www.P65Warnings.ca.gov



KEY FEATURES

- ✓ Safe and quick installation and removal of the conductor.
- ✓ Variety of sizes to accommodate conductors from 0.16 to 1.50 inch diameter
- ✓ All moving parts of the clamps are captive.
- ✓ Made from heat treated aluminium alloy 356-T6 or ductile iron 60-45-15
- ✓ Hot dip galvanised for corrosion resistance

Our Suspension Clamps and Hold Down Weights are just two examples of pole line hardware products developed as part of our solutions-based approach.

They're standards-compliant product equivalents providing safe and quick installation and removal of conductors when attached to insulators. A single fastener fully opens and closes the jaw.

Now a Slingco inventoried product, the clamps come in a variety of sizes to accommodate conductors from 0.16 to 1.50 inch diameter, and loadings of up to 18,000 lbs. To prevent loss, all moving parts of the clamps are captive.

Depending on size, the clamps are either made from heat treated aluminum alloy 356-T6 or ductile iron 60-45-15 and hot dip galvanized for corrosion resistance.



GET IN TOUCH

- ☎ 1 888 685 9478
- ✉ sales@slingcoamerica.com

POLE LINE SUSPENSION CLAMPS

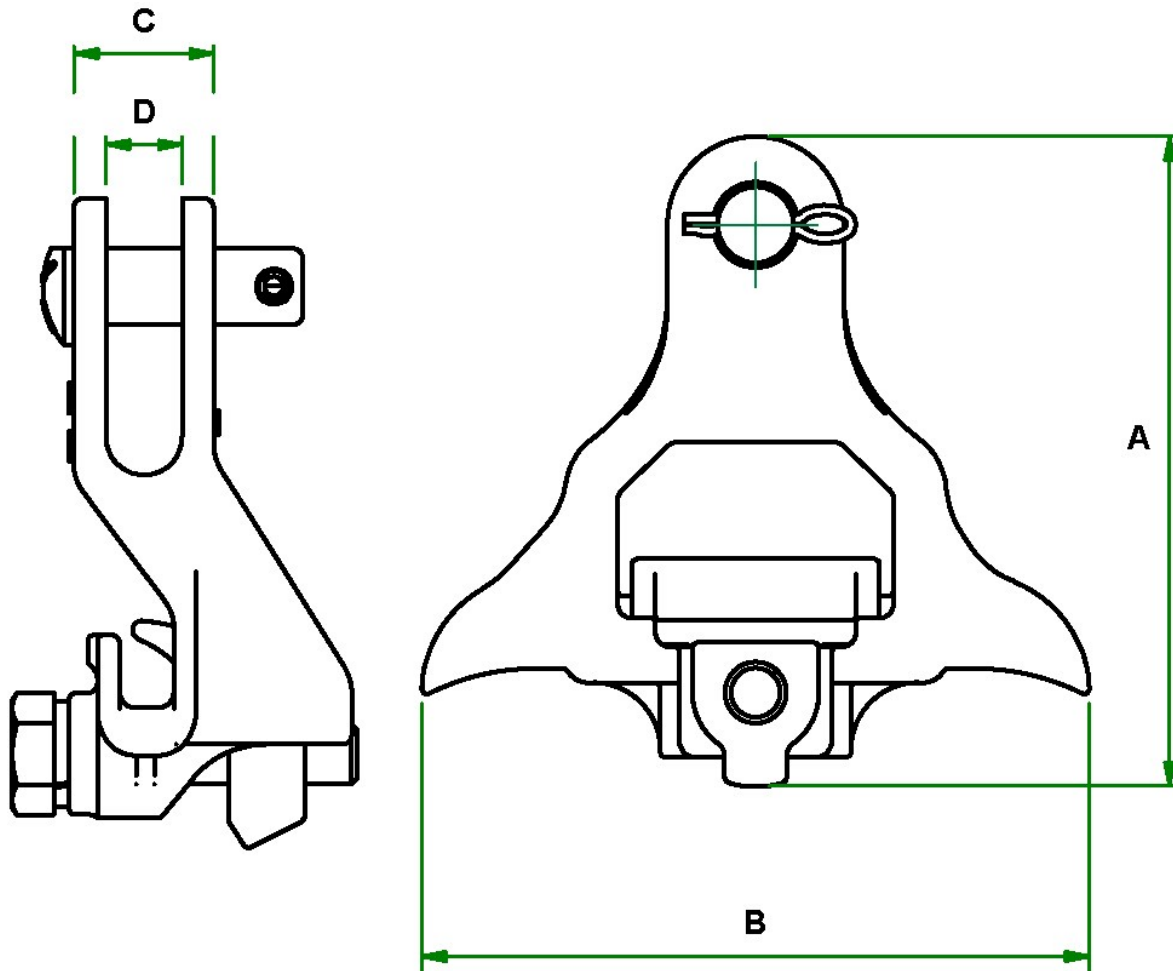

Slingco Part No.	Range (in)	Material	A (in)	B (in)	C (in)	D (in)	Load (lbs)
ZMI6320	0.16 – 0.43	Ductile iron	5.36	5.51	1.16	0.63	10,000
ZMI6321	0.30 – 0.70	Ductile iron	8.03	6.34	1.38	0.63	18,000
ZMI6322	0.50 – 0.687	Aluminum alloy 356-T6	6.22	6.89	1.61	0.63	12,000
ZMI6323	0.68 – 1.00	Aluminum alloy 356-T6	8.37	6.89	1.73	0.63	12,000
ZMI6324	1.00 – 1.313	Aluminum alloy 356-T6	9.53	6.97	1.74	0.63	12,000

This information is for marketing purposes only. The details contained herein is presented as general information and no representation or warranty is expressly or impliedly given as to its accuracy, completeness or correctness. It does not constitute part of a legal offer or contract. For technical specifications, please contact Slingco America, Inc.

Dimensions

The figures shown are indicative only. Fully dimensioned data-sheets are available on request. Nominal figures/actuals are as per data-sheet with tolerances of +/-10%. Please contact us if you have any questions.



GET IN TOUCH

1 888 685 9478

sales@slingcoamerica.com

POLE LINE SUSPENSION CLAMPS

Range dimension overlaps If the cable, rope or hose you have lies where ranges overlap, e.g. 1" when sizing is 0.5-1.00 and 1.00-1.5 we recommend that you select your cable grip to achieve break load first. If tensile strengths are equal or both adequate, choose the smaller of the two. Please contact us if you have any questions.



GET IN TOUCH



1 888 685 9478



sales@slingcoamerica.com