



Fiberglass Extension Arms

Versatile mounting
options for temporary
movement of cables



Fiberglass Extension Arms

Versatile mounting options for temporary movement of cables

Slingco Fiberglass Extension Arms are used to move conductor to create working clearance in congested areas, or as a temporary aid in replacing insulators and/or conductor.

The Fiberglass Extension Arm complies with ASTM F711, OSHA 1910.269 (j)(l), and OSHA 1926.957 (a)(l).

The arm is rated for 34.5kV with insulators and 15kV without insulators. It includes a double bracket system that will fit over crossarms up to 6" x 6". The wire holders will accommodate cables up to 1.6" in diameter.

The Slingco Fiberglass Extension Arm includes a QR code so the manual and instructions are always accessible in the field - just scan to view on your mobile.

Slingco offers an optional retrofit kit to protect fiberglass crossarms when the extension arm is installed. The retrofit kit ensures the eye bolts do not penetrate the crossarm.

Use the parts diagrams to order parts as replacements or add-ons. Convert 15kV model to 34.5kV by adding insulators.

- ✓ ASTM F711 compliant
- ✓ Dual crossarm brackets to fit up to a 6" x 6" crossarm
- ✓ Wireholders for up to 1.6" cable
- ✓ Rated for 34.5kV with insulators and 15kV without insulators
- ✓ Easy to install
- ✓ Furnished with bronze eye bolts

Part No.	Description	Weight (lb)	Weight (kg)	Phase-to-Phase Rating (as supplied)	Max Vertical Load per Wireholder lb (kg)
ITP10989	Crossarm FEA without Insulators	21.2	9.62	15kV	200 (90.72)
ITP10474	Crossarm FEA with Insulators	23.4	10.61	34.5kV	200 (90.72)
ITP14754	Chain Binder Single Conductor	16.5	7.48	34.5kV	200 (90.72)
ITP14726	Chain Binder Double Conductor	21.6	9.79	34.5kV	200 (90.72)
ITP14767	Ratchet Strap Single Conductor	14.8	6.70	34.5kV	200 (90.72)
ITP14771	Ratchet Strap Double Conductor	20.0	9.08	34.5kV	200 (90.72)

REPLACEMENT PARTS FOR ITP10989 & ITP10474

OPTIONAL ACCESSORY

ATTENTION

Remove and retain these tags along with the manual provided and make available to all personnel.

SAFETY & WARNINGS

Fiberglass Extension Arm is for temporary use only, as defined and provided.

Use in clean, dry and gloved, hand finish, the following:

- 0.22kg (0.5 lb) Max. Load
- 0.35 kg Side Load per wireholder
- See also ITP10925* for details of 1' from between wireholders
- Phase-to-Phase with insulators

©2020 Slingco and its subsidiaries. All rights reserved.

Item	Part Number	Description
1	EBW09611	Eye Bolt 5/8"-8 Acme Thread
2	ITP10878	Crossarm Support Assembly
3	ITP09622	Wireholder without Insulator
4	ITP10466	Wireholder with Insulator
5	ITP10352	Insulator
6	LAB12355	Wireholder Location Label
7	LAB14264	Weather Resistant Warning Tags
8	ITP10925*	Fiberglass Crossarm Retrofit Kit

*Optional accessory

REPLACEMENT PARTS FOR ITP14767 & ITP14771

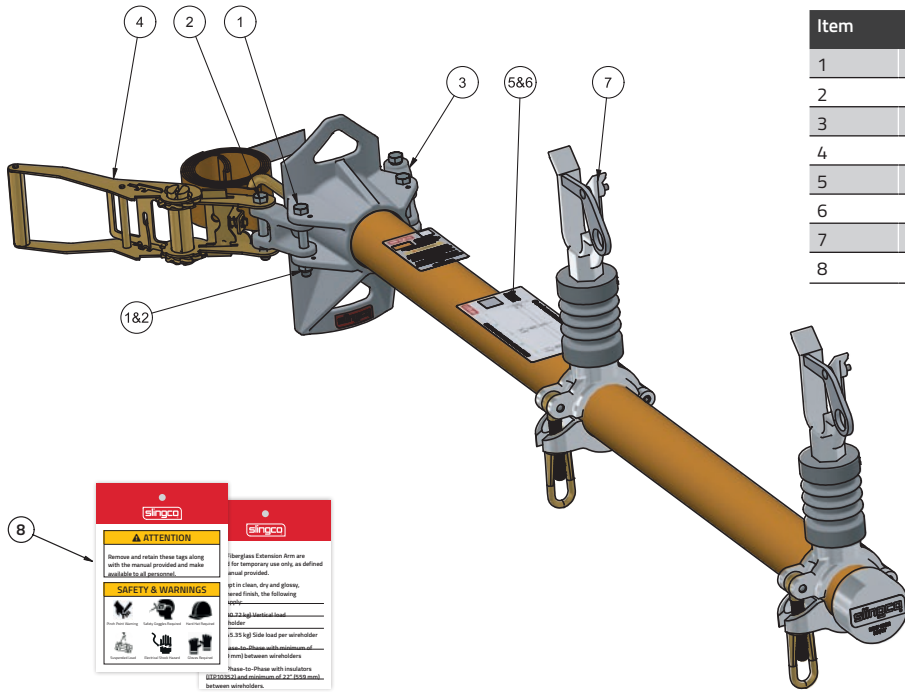

Item	Part Number	Description
1	ITP15388	Hardware for Casting
2	ITP15389	Hardware for Ratchet Strap Connection
3	ITP13342	Ratchet Strap Connection Piece
4	ITP14765	Ratchet Strap
5	LAB13713	Wireholder Label for ITP14767
6	LAB13711	Wireholder Label for ITP14771
7	ITP10466	Wireholder with Insulator
8	LAB14264	Weather Resistant Warning Tags



REPLACEMENT PARTS FOR ITP14754 & ITP14726

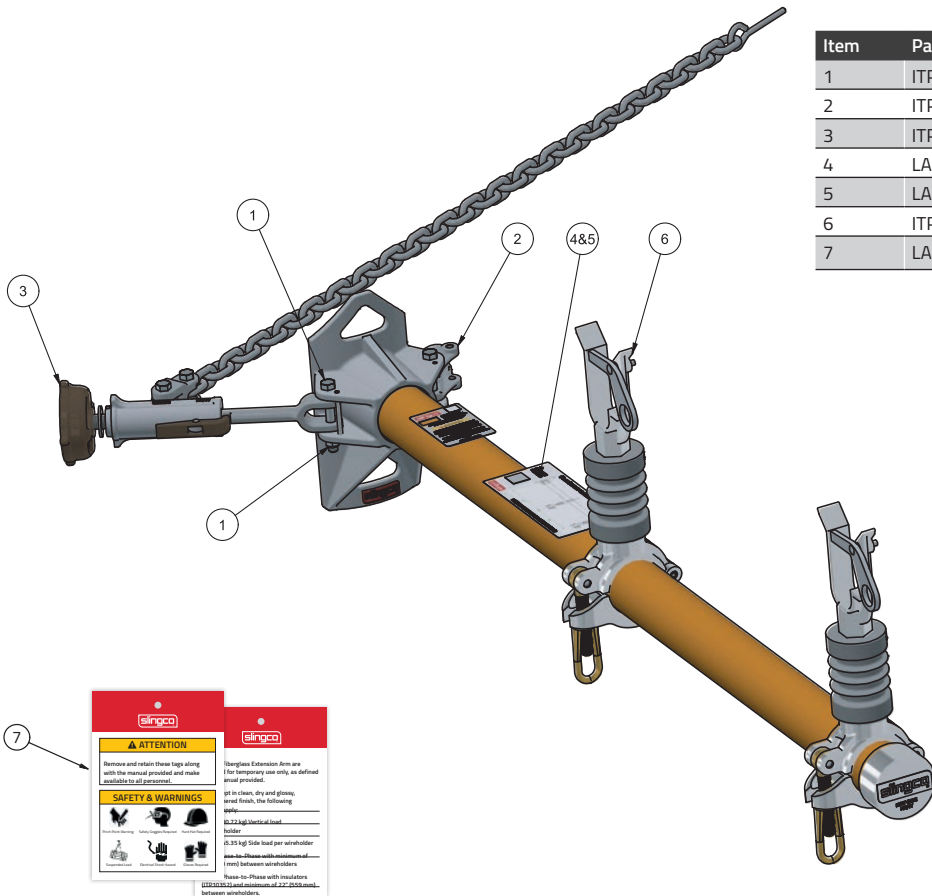

Item	Part Number	Description
1	ITP15388	Hardware for Casting
2	ITP13205	Chain Holder Casting
3	ITP14727	Chain Binder Assembly
4	LAB13328	Wireholder Label for ITP14754
5	LAB13327	Wireholder Label for ITP14726
6	ITP10466	Wireholder with Insulator
7	LAB14264	Weather Resistant Warning Tags





Slingco America, Inc.

3100 Jonquil Drive SE, Smyrna, Georgia, 30080, USA

TOLL FREE: 888 685 9478 · sales@slingcoamerica.com

For any inquiries call or visit

888 685 9478 | [slingco.com](https://www.slingco.com)

Slingco makes no warranty, express or implied, with respect to this product nor with respect to its specifications. In no event shall Slingco be liable for any direct, indirect, punitive, incidental, special consequential damages to property or life, whatsoever, arising out of or connected with the use or misuse of this product. This product is intended for use by qualified professionals having adequate knowledge of its proper use. December 2025 - v1.3